

NOTES:

1. Material: UVFS;
2. G - Fine ground surface;
3. All dimensions are in mm;
4. Protective chamfers: 0.3 mm x 45°;
5. Angle tolerance:  $\alpha=79.5^\circ \pm 0.5^\circ$ ,  $\beta=60^\circ \pm 1^\circ$ ;

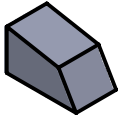

Isometric view 1:2

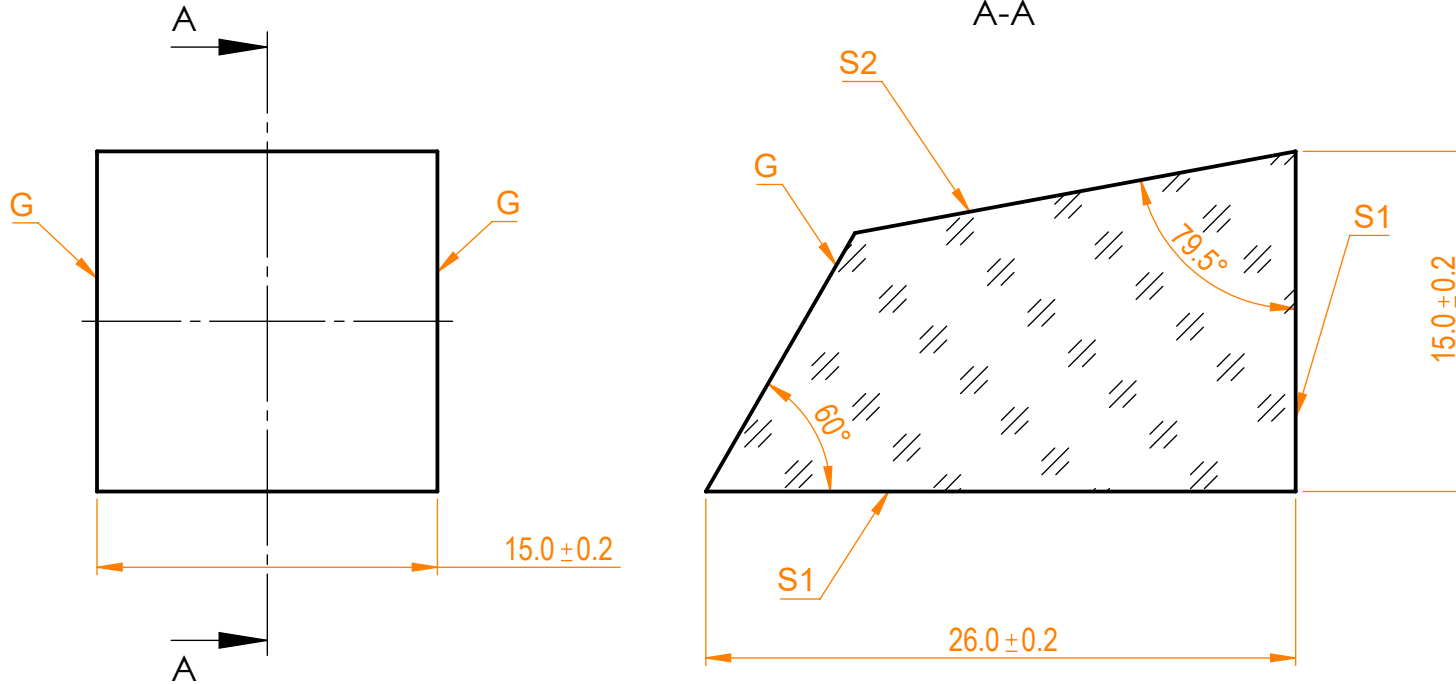

Specifications are subject to change without notice  
Dimensions are for reference only

Parameters

	S1	S2
Shape	Plano	Plano
Surface flatness	$\lambda/10$ @633nm	$\lambda/10$ @633nm
Surface quality	20-10 s/d	20-10 s/d
Clear aperture	>80%	>80%
Coating	-	-



PB prism, H=15 mm, L=26 mm, T=15 mm

Proprietary	Approved	Name	Date	Part number	Rev.	Scale
The information in this drawing is property of EKSMA Optics. Any reproduction in part or as a whole without the written permission of EKSMA Optics is prohibited.	Approved	A.K.	2020.12.14	325-1215	A	3:1
	Drawn	V.S.	2020.12.14			