

NOTES:
 1. Material: UVFS;
 2. G - Fine ground surface;
 3. All dimensions are in mm;

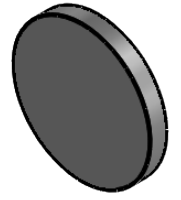

Isometric view 1:1

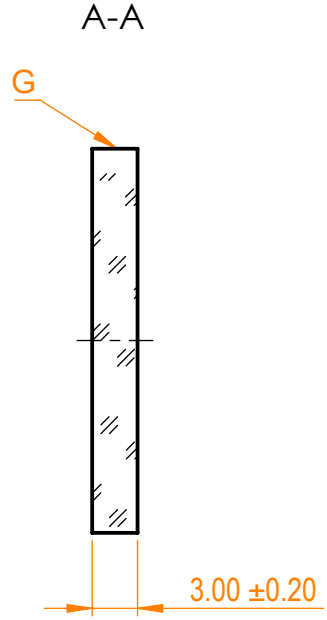
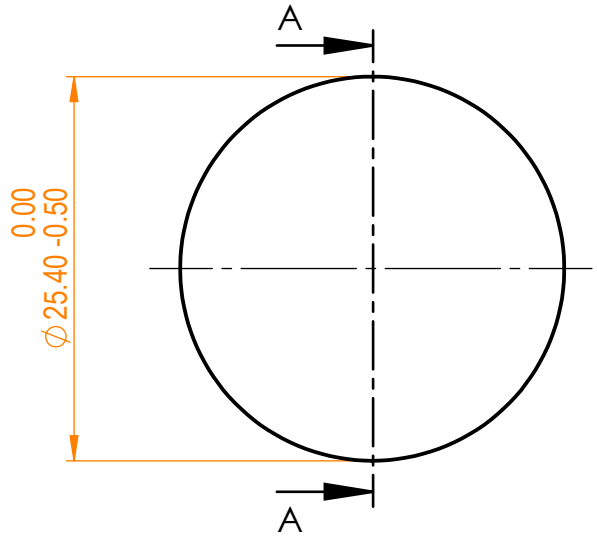

Specifications are subject to change without notice
 Dimensions are for reference only

Parameters	
Shape	Plano
Surface quality	60-40 s/d
Surface flatness	1 λ @632.8 nm
Clear aperture	≥80%
Protective chamfers	0.2 - 0.3 mm x 45°
Parallelism	2 arcmin



UVFS pl window, D=25.4 mm, T=3 mm

Proprietary	Approved	Name	Date	Part number	Rev.	Scale
The information in this drawing is property of EKSMA Optics. Any reproduction in part or as a whole without the written permission of EKSMA Optics is prohibited.	Drawn	A.K.	2019.11.18	210-1203E	A	2:1
		A.F.	2019.11.18			