

NOTES:

1. Material: UVFS;
2. G - Fine ground surface;
3. All dimensions are in mm;
4. Wedge: <3 min;
5. Protective chamfers: 0.3 mm x 45°;
6. Laser Induced Damage Threshold:
 - > 0.25 J/cm² at @800nm, 50Hz, 94fsec pulses,
 - > 1.8 J/cm² at @1064nm, 50Hz, 11nsec pulses;

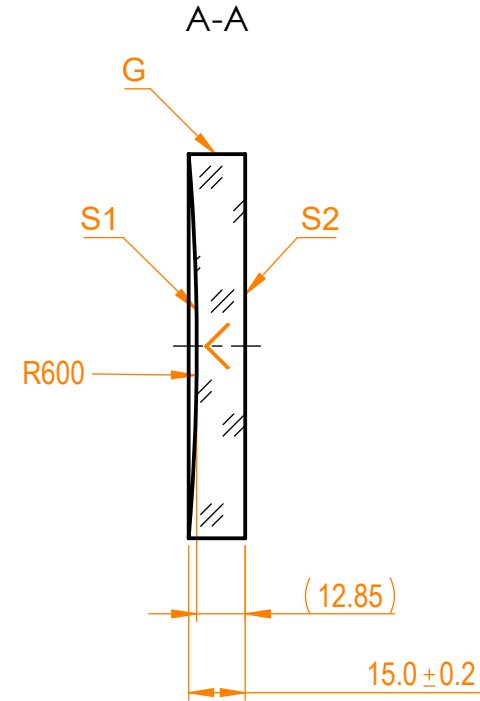

Isometric view 1:8

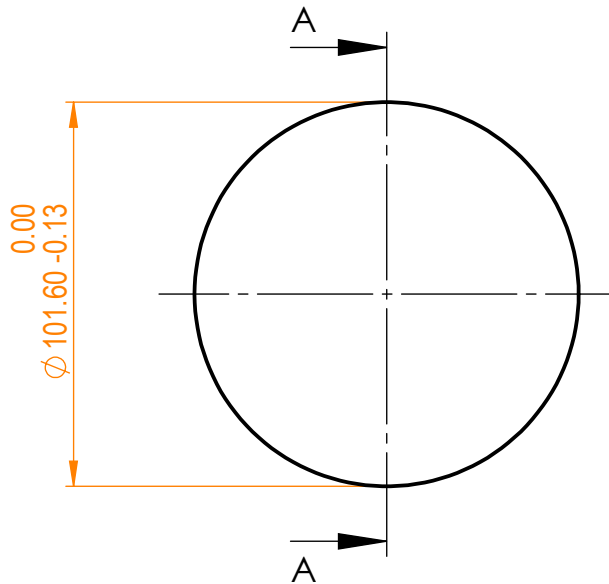

Specifications are subject to change without notice
 Dimensions are for reference only

Parameters		S1		S2		UVFS pl/cv mirror, D=101.6 mm, T=15 mm						
Shape	Radius of curvature	Surface flatness	Surface quality	Clear aperture	Coating			Proprietary	Approved			
		$\lambda/10$ @633nm	40-20 s/d	>90%	Protected silver R _{avg} >96%@400nm - IR	The information in this drawing is property of EKSMA Optics. Any reproduction in part or as a whole without the written permission of EKSMA Optics is prohibited.	Approved	Name	Date	Part number	Rev.	Scale
		λ @633nm per inch	80-50 s/d	>90%	Uncoated		Drawn	A.K.	2020.11.16	098-3125R-600	A	1:2
								V.S.	2020.11.16			