

NOTES:

1. Material: UVFS;
2. G - Fine ground surface;
3. All dimensions are in mm;
4. Wedge: <3 min;
5. Protective chamfers: 0.3 mm x 45°;
6. Laser Induced Damage Threshold: > 1 J/cm² at @1064nm, 50Hz, 11nsec pulses;

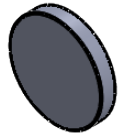

Isometric view 1:6

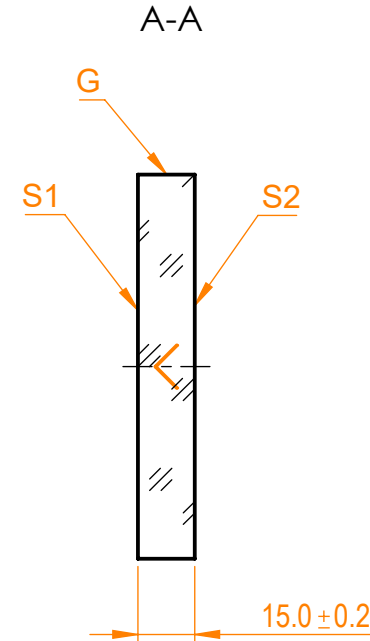
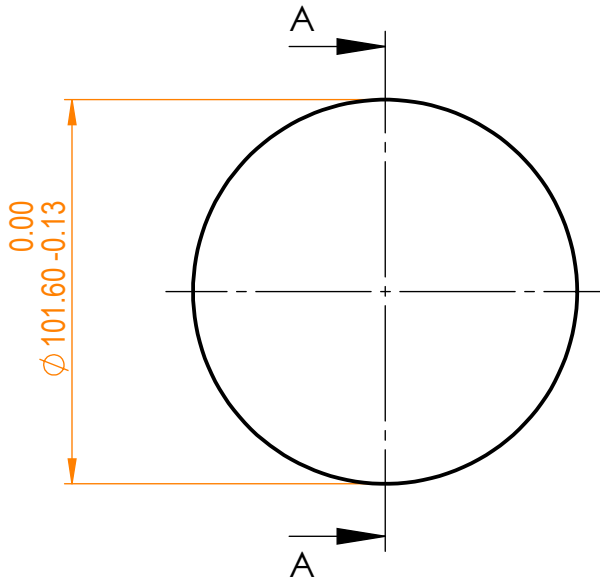

Specifications are subject to change without notice
 Dimensions are for reference only

Parameters				 info@eksmaoptics.com www.eksmaoptics.com		UVFS pl mirror, D=101.6 mm, T=15 mm				
	S1	S2								
Shape	Plano	Plano		Proprietary The information in this drawing is property of EKSMA Optics. Any reproduction in part or as a whole without the written permission of EKSMA Optics is prohibited.	Name	Date	Part number	Rev.	Scale	
Radius of curvature	Infinity	Infinity			Approved	A.K.	2020.12.03	098-3030	A	1:2
Surface flatness	$\lambda/10$ @633nm	λ @633nm per inch			Drawn	V.S.	2020.12.03			
Surface quality	40-20 s/d	80-50 s/d								
Clear aperture	>90%	>90%								
Coating	Protected gold Ravg>98%@900nm - IR	Uncoated								