

**NOTES:**

1. Material: UVFS;
2. G - Fine ground surface;
3. All dimensions are in mm;
4. Wedge: <3 min;
5. Protective chamfers: 0.3 mm x 45°;
6. Laser Induced Damage Threshold:
  - > 0.25 J/cm<sup>2</sup> at @800nm, 50Hz, 94fsec pulses,
  - > 1.8 J/cm<sup>2</sup> at @1064nm, 50Hz, 11nsec pulses;

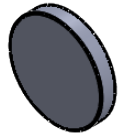

Isometric view 1:6

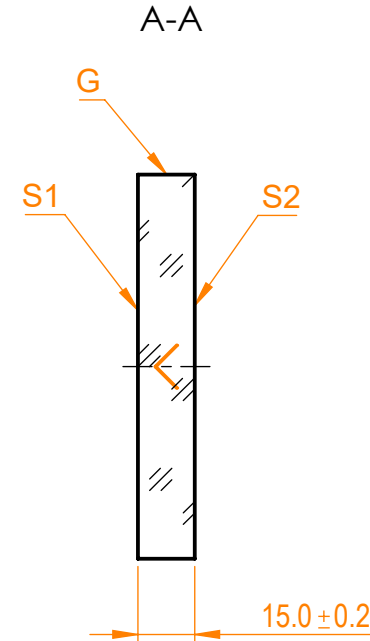
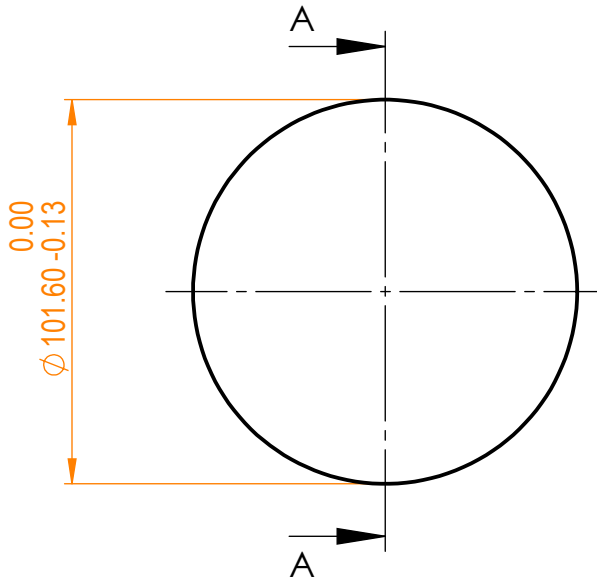

Specifications are subject to change without notice  
 Dimensions are for reference only

Parameters				 info@eksmaoptics.com www.eksmaoptics.com		UVFS pl mirror, D=101.6 mm, T=15 mm			
	S1	S2							
Shape	Plano	Plano		Proprietary	Name	Date	Part number	Rev.	Scale
Radius of curvature	Infinity	Infinity			Approved	A.K.	2020.12.03	098-3025	A
Surface flatness	$\lambda/10$ @633nm	$\lambda$ @633nm per inch		The information in this drawing is property of EKSMA Optics. Any reproduction in part or as a whole without the written permission of EKSMA Optics is prohibited.	Drawn	V.S.	2020.12.03		
Surface quality	40-20 s/d	80-50 s/d							
Clear aperture	>90%	>90%							
Coating	Protected silver R <sub>avg</sub> >96%@400nm - IR	Uncoated							