

NOTES:

1. Material: UVFS;
2. G - Fine ground surface;
3. All dimensions are in mm;
4. Wedge: <3 min;
5. Protective chamfers: 0.3 mm x 45°;
6. Laser Induced Damage Threshold:
 - > 0.25 J/cm² at @800nm, 50Hz, 94fsec pulses,
 - > 1.8 J/cm² at @1064nm, 50Hz, 11nsec pulses;

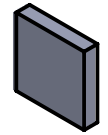

Isometric view 1:4

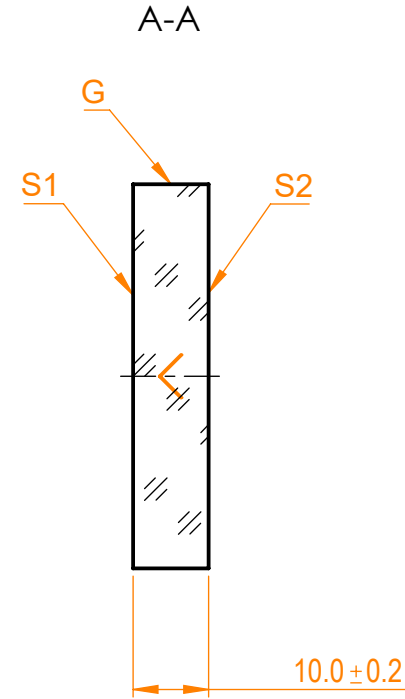
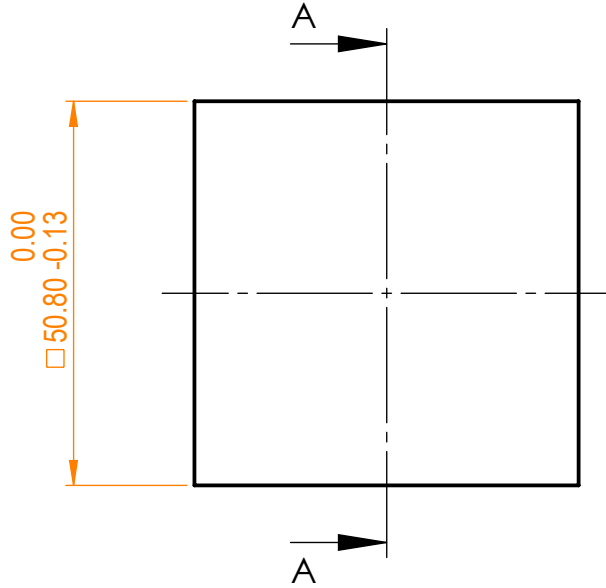

Specifications are subject to change without notice
Dimensions are for reference only

Parameters				 info@eksmaoptics.com www.eksmaoptics.com		UVFS pl mirror, (50.8x50.8) mm, T=10 mm				
	S1	S2								
Shape	Plano	Plano		Proprietary	Name	Date	Part number	Rev.	Scale	
Radius of curvature	Infinity	Infinity		The information in this drawing is property of EKSMA Optics. Any reproduction in part or as a whole without the written permission of EKSMA Optics is prohibited.	A.K.	2020.09.14	095-3325	A	1:1	
Surface flatness	$\lambda/10$ @633nm	λ @633nm per inch			Approved	V.S.				2020.09.14
Surface quality	40-20 s/d	80-50 s/d		Drawn						
Clear aperture	>90%	>90%								
Coating	Protected silver R _{avg} >96%@400nm - IR	Uncoated								