

NOTES:
 1. Material: UVFS;
 2. G - Fine ground surface;
 3. All dimensions are in mm;

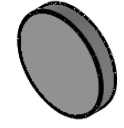

Isometric view 1:5

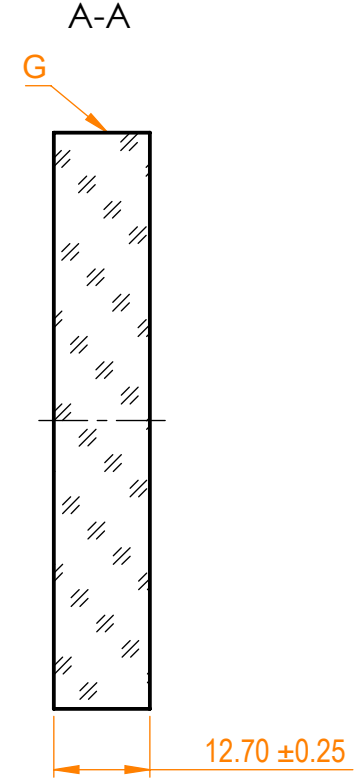
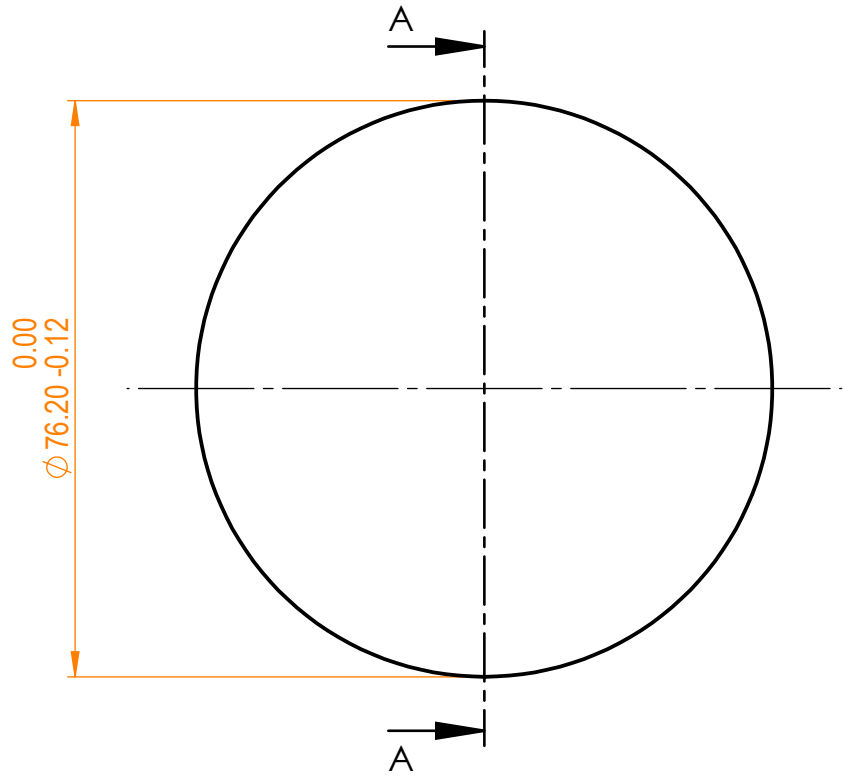

Specifications are subject to change without notice
 Dimensions are for reference only

Parameters		EKSMA OPTICS		UVFS pl mirror, D=76.2 mm, T=12.7 mm					
Shape	Plano	 info@eksmaoptics.com www.eksmaoptics.com		Proprietary	Name	Date	Part number	Rev.	Scale
S1 Surface flatness	$\lambda/10$ @632.8 nm				Approved	A.K.	2019.12.19	067-5103-i0	A
S1 Surface quality	20-10 s/d			Drawn		A.F.	2019.12.19		
S2 Surface quality	Commercial polish				The information in this drawing is property of EKSMA Optics. Any reproduction in part or as a whole without the written permission of EKSMA Optics is prohibited.				
Clear aperture	$\geq 85\%$								
Protective chamfers	0.2 - 0.3 mm x 45°								
Wedge	<3 minutes								
Coating	HR _{(s+p)/2} >99.5% @500-530+1000-1060nm, AOI=0°								