

NOTES:
 1. Material: UVFS;
 2. G - Fine ground surface;
 3. All dimensions are in mm;

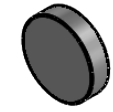

Isometric view 1:1

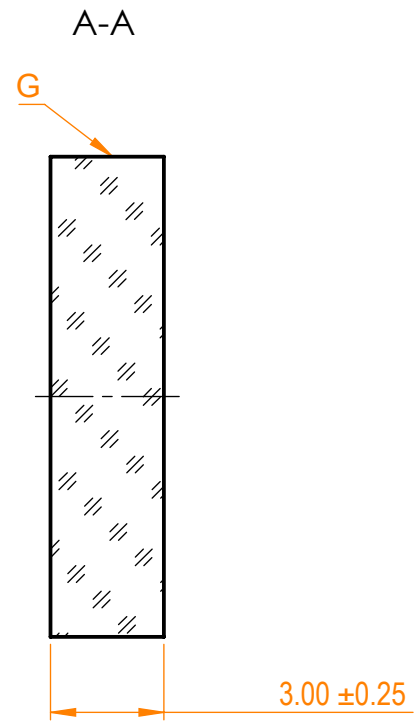
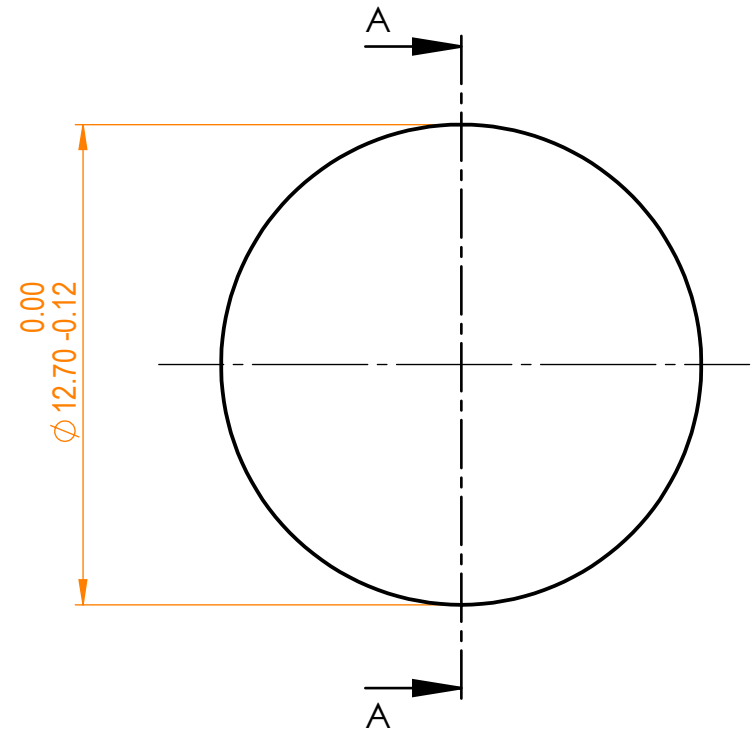

Specifications are subject to change without notice
 Dimensions are for reference only

Parameters		EKSMA OPTICS		UVFS pl mirror, D=12.7 mm, T=3 mm				
Shape	Plano	 info@eksmaoptics.com www.eksmaoptics.com		Name	Date	Part number	Rev.	Scale
S1 Surface flatness	$\lambda/10$ @632.8 nm							
S1 Surface quality	20-10 s/d	Proprietary	Approved	A.K.	2019.12.19	061-5103	A	5:1
S2 Surface quality	Commercial polish			A.F.	2019.12.19			
Clear aperture	≥85%	The information in this drawing is property of EKSMA Optics. Any reproduction in part or as a whole without the written permission of EKSMA Optics is prohibited.						
Protective chamfers	0.2 - 0.3 mm x 45°							
Wedge	<3 minutes							
Coating	HR _{(s+p)/2} >99.5% @500-530+1000-1060nm, AOI=45°							