

NOTES:

1. Material: UVFS;
2. G - Fine ground surface;
3. All dimensions are in mm;
4. Wedge: <3 minutes;
5. Protective chamfers: 0.3 mm x 45°;
6. Laser Induced Damage Threshold: >10 J/cm² at @355nm, 100Hz, 10nsec pulses;

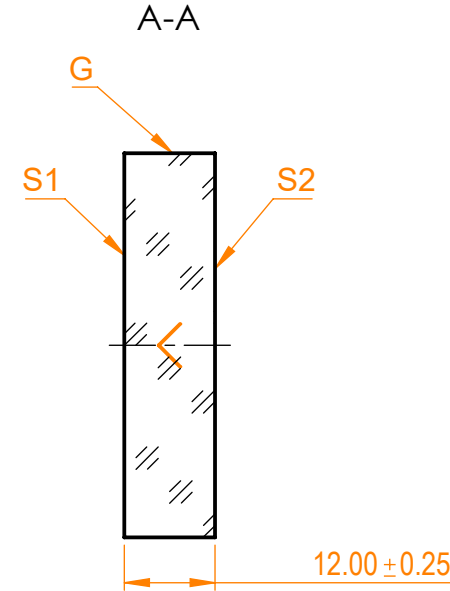

Isometric view 1:2

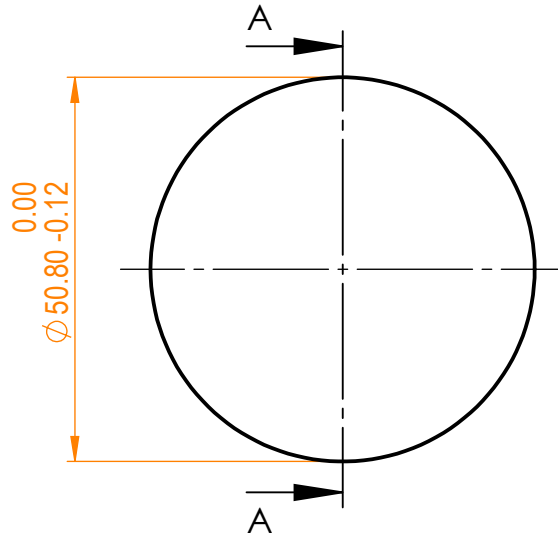

Specifications are subject to change without notice
 Dimensions are for reference only

Parameters		
	S1	S2
Shape	Plano	Plano
Radius of curvature	Infinity	Infinity
Surface flatness	$\lambda/10$ @633nm	λ @633nm per inch
Surface quality	20-10 s/d	80-50 s/d
Clear aperture	≥85%	≥85%
Coating	HR _{(s+p)/2} >99.8%@355nm, AOI=45°	Uncoated

info@eksmaoptics.com
www.eksmaoptics.com

UVFS pl mirror, D=50.8 mm, T=12 mm

Proprietary		Name	Date	Part number	Rev.	Scale
The information in this drawing is property of EKSMA Optics. Any reproduction in part or as a whole without the written permission of EKSMA Optics is prohibited.	Approved	A.K.	2020.09.10	045-0350 UHHR	A	1:1
	Drawn	V.S.	2020.09.10			