

NOTES:

1. Material: UVFS;
2. G - Fine ground surface;
3. All dimensions are in mm;
4. Wedge: <3 minutes;
5. Protective chamfers: 0.3 mm x 45°;
6. Laser Induced Damage Threshold: >1 J/cm² at @515nm, 20kHz, 10psec pulses;

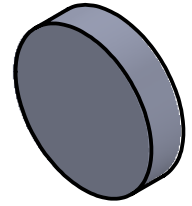

Isometric view 1:1

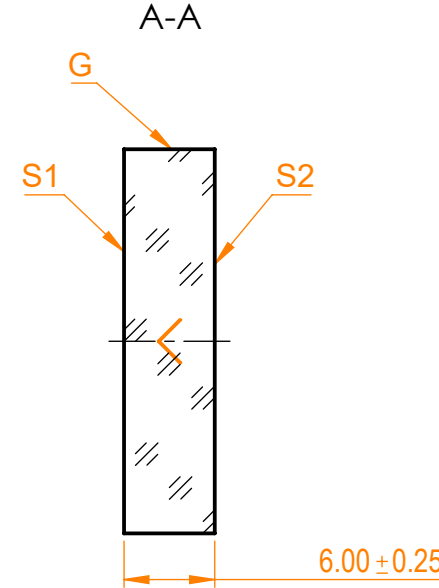
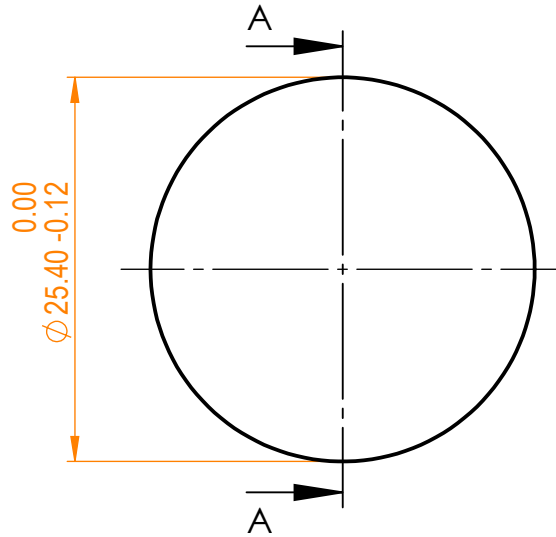

Specifications are subject to change without notice
Dimensions are for reference only

Parameters			 info@eksmaoptics.com www.eksmaoptics.com	UVFS pl mirror, D=25.4 mm, T=6 mm					
	S1	S2		Proprietary	Name	Date	Part number	Rev.	Scale
Shape	Plano	Plano	The information in this drawing is property of EKSMA Optics. Any reproduction in part or as a whole without the written permission of EKSMA Optics is prohibited.	Approved	A.K.	2020.09.10	042-0515PHR	A	2:1
Radius of curvature	Infinity	Infinity		Drawn	V.S.	2020.09.10			
Surface flatness	$\lambda/10$ @633nm	λ @633nm per inch							
Surface quality	20-10 s/d	80-50 s/d							
Clear aperture	≥85%	≥85%							
Coating	HR _(s+p) /2>99.9%@515nm, AOI=45°	Uncoated							