

NOTES:

1. Material: UVFS;
2. Wedge: <30 arcsec;
3. LDT: >100 mJ/cm², 50 fsec, 100Hz, 800 nm;
4. Coating adhesion and durability: MIL-C-675A;
5. Protective chamfers: 0.2 - 0.3 mm x 45°;
6. G - Fine ground surface;
7. All dimensions are in mm;

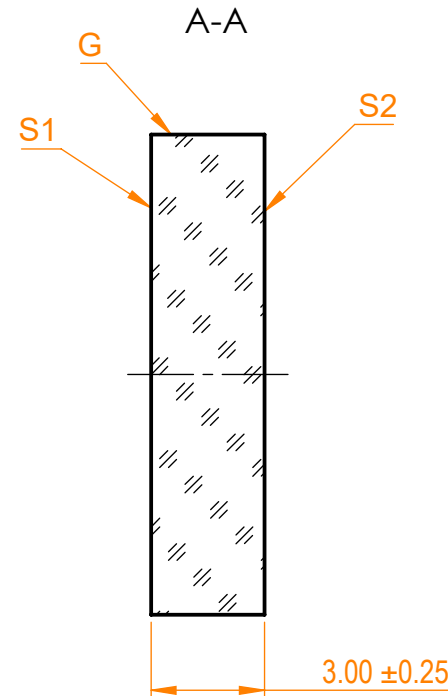

Isometric view 1:1

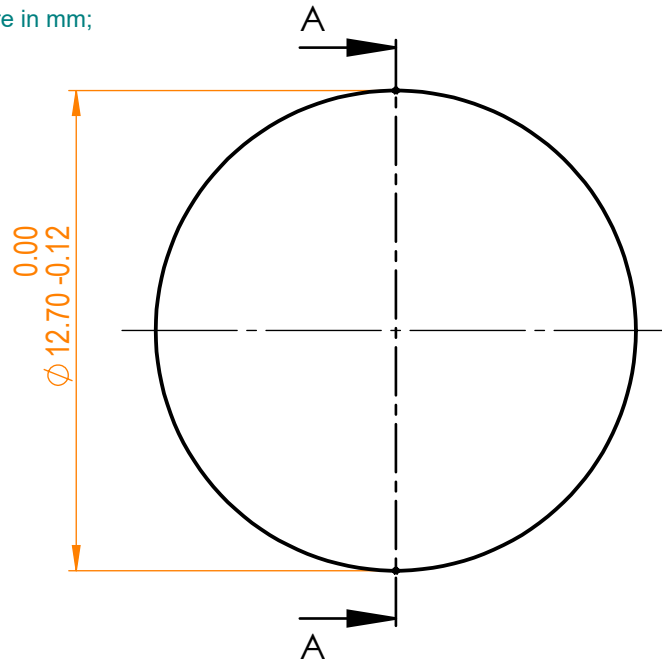

Specifications are subject to change without notice
 Dimensions are for reference only

| Parameters | | |
|------------------|---|------------------------|
| | S1 | S2 |
| Shape | Plano | Plano |
| Surface quality | 20-10 s/d | 20-10 s/d |
| Surface flatness | $\lambda/10$ @632.8 nm | $\lambda/10$ @632.8 nm |
| Clear aperture | ≥85% | ≥85% |
| Coating | R>99%@1030nm + T<95%@515nm, AOI=0°, Low GDD | AR<0.25%@515nm, AOI=0° |



D=12.7 mm, Femtoline Harmonic Separator

| Proprietary | Approved | Name | Date | Part number | Rev. | Scale |
|---|----------|------|------------|-------------|------|-------|
| The information in this drawing is property of EKSMA Optics. Any reproduction in part or as a whole without the written permission of EKSMA Optics is prohibited. | Approved | A.K. | 2021.01.11 | 041-6510 | A | 5:1 |
| | Drawn | M.B. | 2021.01.11 | | | |