

NOTES:

1. Material: UVFS;
2. G - Fine ground surface;
3. All dimensions are in mm;
4. Wedge: <3 minutes;
5. Protective chamfers: 0.3 mm x 45°;
6. Laser Induced Damage Threshold: >0.4 J/cm² at @1030nm, 100Hz, 50fsec pulses;

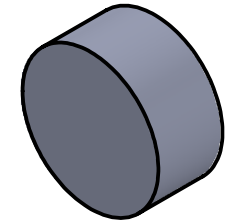

Isometric view 2:1

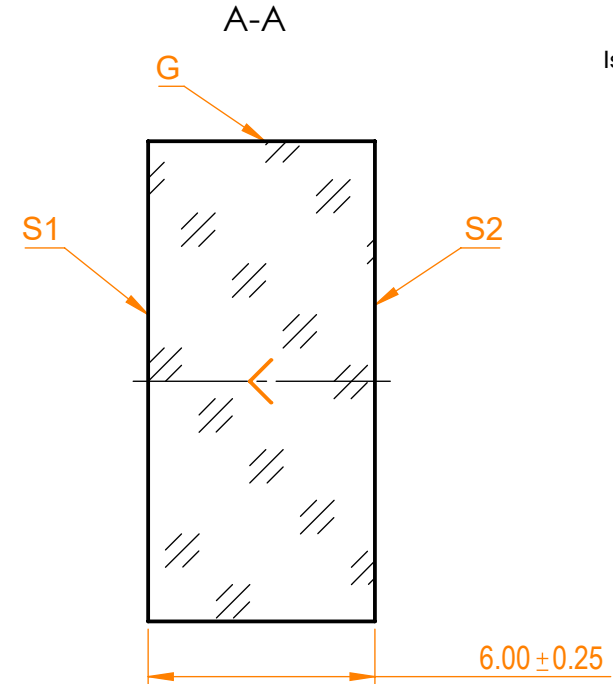
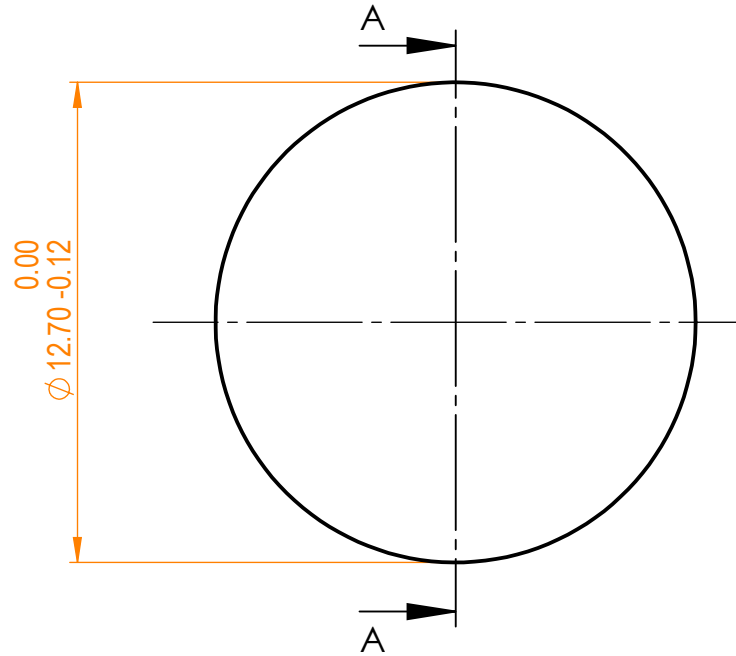

Specifications are subject to change without notice
Dimensions are for reference only

Parameters						UVFS pl mirror, D=12.7 mm, T=6 mm				
	S1	S2								
Shape	Plano	Plano								
Radius of curvature	Infinity	Infinity								
Surface flatness	$\lambda/10$ @633nm	λ @633nm per inch								
Surface quality	20-10 s/d	80-50 s/d								
Clear aperture	≥85%	≥85%								
Coating	HR _{(s+p)/2} >99.9%@1000-1060nm, AOI=45°	Uncoated								
				Proprietary		Name	Date	Part number	Rev.	Scale
				The information in this drawing is property of EKSMA Optics. Any reproduction in part or as a whole without the written permission of EKSMA Optics is prohibited.	Approved	A.K.	2020.09.09	041-1030T6 HHR	A	5:1
					Drawn	V.S.	2020.09.09			