

NOTES:

1. Material: UVFS;
2. G - Fine ground surface;
3. All dimensions are in mm;
4. Wedge: <3 minutes;
5. Protective chamfers: 0.3 mm x 45°;
6. Laser Induced Damage Threshold: >3 J/cm² at @1030nm, 20kHz, 10psec pulses;

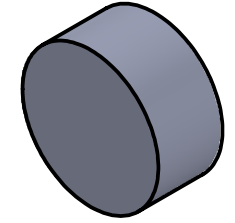

Isometric view 2:1

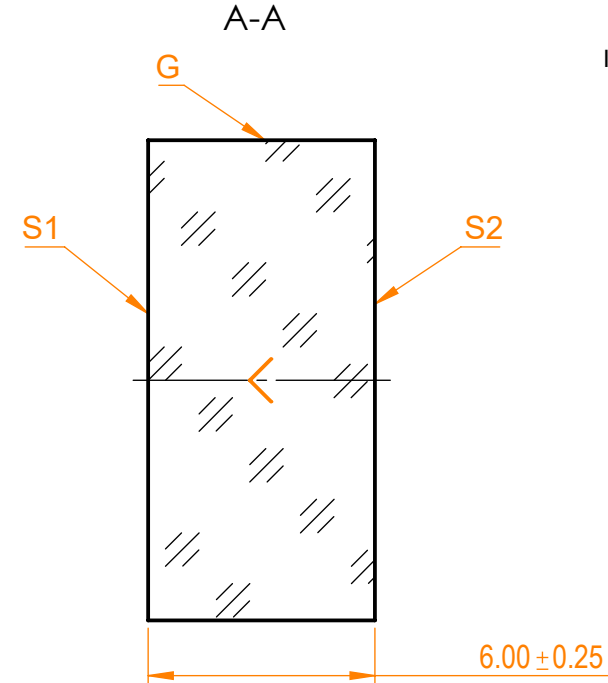
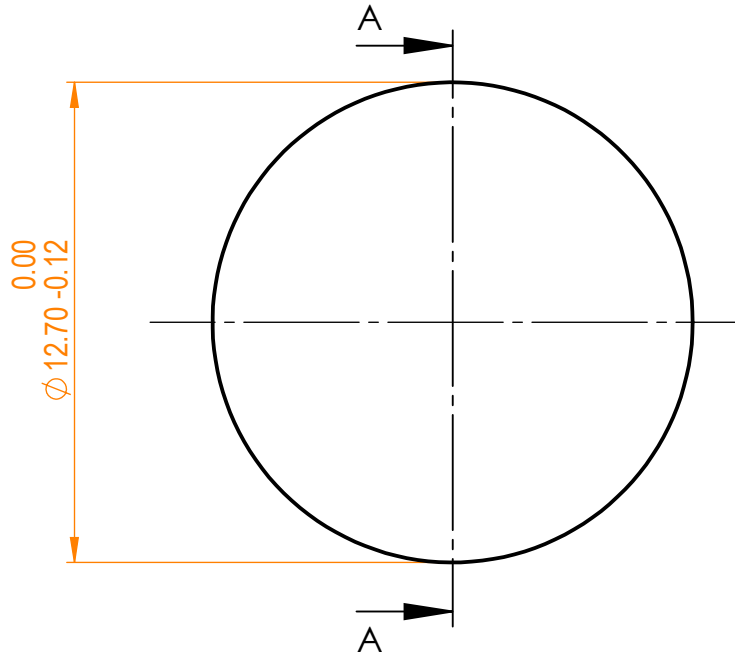

Specifications are subject to change without notice
Dimensions are for reference only

Parameters				 info@eksmaoptics.com www.eksmaoptics.com		UVFS pl mirror, D=12.7 mm, T=6 mm				
	S1	S2								
Shape	Plano	Plano		Proprietary		Name	Date	Part number	Rev.	Scale
Radius of curvature	Infinity	Infinity		The information in this drawing is property of EKSMA Optics. Any reproduction in part or as a whole without the written permission of EKSMA Optics is prohibited.	Approved	A.K.	2020.09.10	041-1030 PUHR	A	5:1
Surface flatness	$\lambda/10$ @633nm	λ @633nm per inch				Drawn	V.S.			
Surface quality	20-10 s/d	80-50 s/d								
Clear aperture	≥85%	≥85%								
Coating	HR _{(s+p)/2} >99.9%@1030nm, AOI=45°	Uncoated								