

**NOTES:**

1. Material: UVFS;
2. G - Fine ground surface;
3. All dimensions are in mm;
4. Wedge: <3 minutes;
5. Protective chamfers: 0.3 mm x 45°;
6. Laser Induced Damage Threshold: >0.2 J/cm<sup>2</sup> at @800nm, 100Hz, 50fsec pulses;

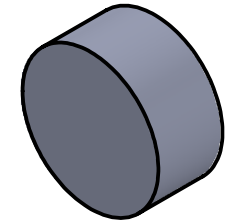

Isometric view 2:1

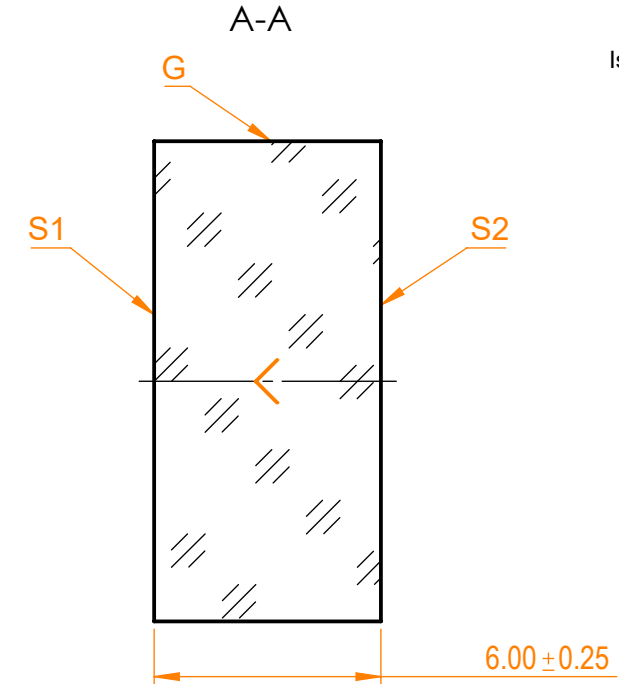
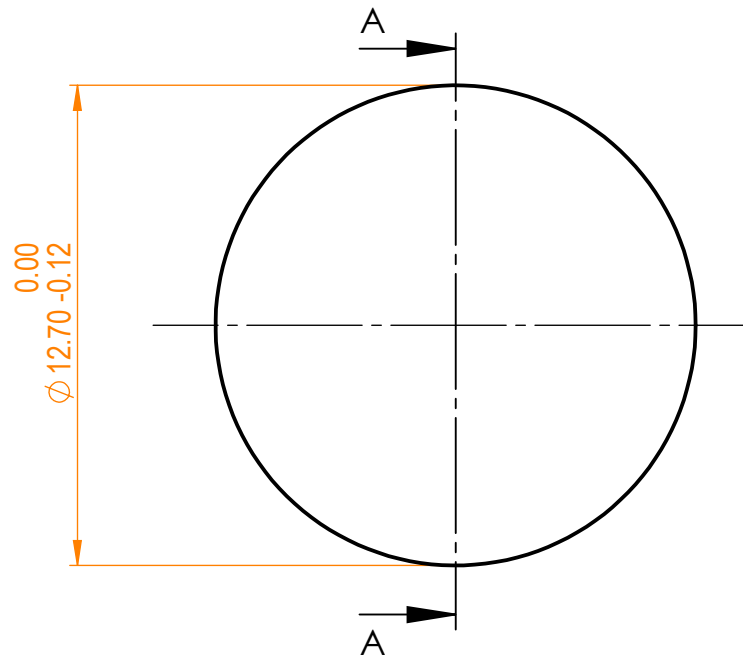

Specifications are subject to change without notice  
 Dimensions are for reference only

		Parameters		 info@eksmaoptics.com www.eksmaoptics.com		UVFS pl mirror, D=12.7 mm, T=6 mm				
		S1	S2			Name	Date	Part number	Rev.	Scale
Shape		Plano	Plano	Proprietary	Approved	A.K.	2020.09.09	041-0800T6 HHR-i0-45	A	5:1
Radius of curvature		Infinity	Infinity							
Surface flatness		$\lambda/10$ @633nm	$\lambda$ @633nm per inch							
Surface quality		20-10 s/d	80-50 s/d							
Clear aperture		≥85%	≥85%							
Coating		HR(s+p)/2>99.9%@760-840nm, AOI=0-45°	Uncoated							