

FemtoLine

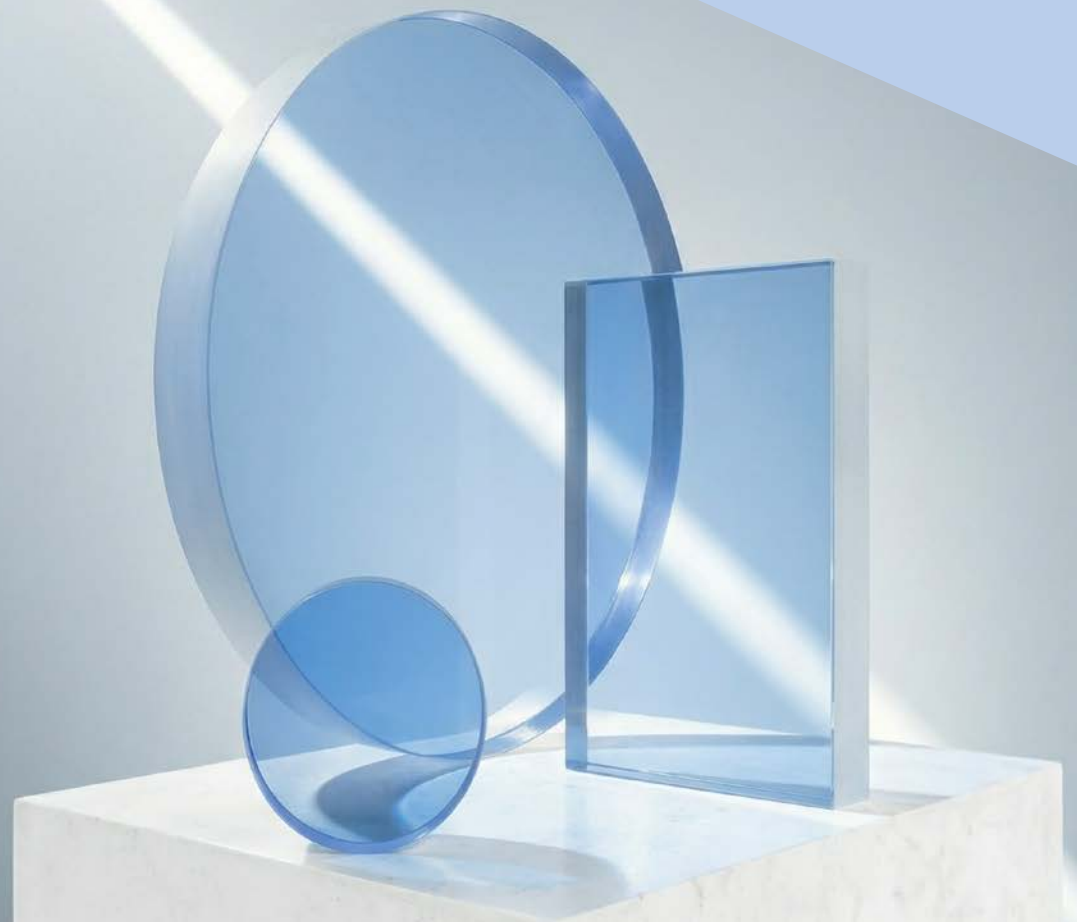

Components for
Seamless Integration
with Industry Leading
Femtosecond
Lasers



Laser Mirrors
Thin Lenses
Polarizing Optics

Optical Assemblies
Nonlinear &
Laser Crystals



EKSMA Optics is a manufacturer of precision laser components, used in high power lasers, laser systems and various other photonic devices and optical instruments. Rooted in laser community and with more than 40 years of experience in lasers and photonic components EKSMA Optics is your partner for enabling photonics innovations, offering fast delivery components tailored to customer applications.

This optical components catalog contains products dedicated to lasers and laser systems manufacturers, integrators, innovators, and scientists. The standard catalog components are available for fast off-the-shelf delivery. We also develop and customize our optical components tailoring the parameters of the particular laser and its applications.

All components provided by EKSMA Optics are subject to performance and quality testing and certification in Quality Control laboratory. Through stringent inspection procedures, quality control assessments and commitment to new advanced technologies, we are continuously improving and delivering exceptional quality. EKSMA Optics is an ISO 9001:2015 & ISO 14001:2015 certified company.

Your Partner in Photonics Innovations!



2022

Establishment of a department for **optical systems assembling**.



2021

Opening and moving to **new 7300 square meters EKSMA Optics building** in Vilnius.



2015

Establishment of a **CNC-based spherical and aspherical lens production**. Commenced production of **pulse picking systems**.



2014

Establishment of a department **dielectric coatings deposition on laser optics and crystals**.



2010

Commenced production of **Pockels cells and Femtokits**.



2007

Investment into and expansion of **flat optics production and nonlinear crystals polishing**.



2006

Establishment of EKSMA's daughter company, **EKSMA Optics**, for laser optics business activities.



1992

State-owned company privatization and **EKSMA UAB** joint-stock company establishment.



1987

First-time participation at Munich Laser Fair. **EKSMA shows picosecond Nd:YAG laser**.



1983

Establishment of experimental optics and opto-mechanics company **EKSMA**, a spin-off from the Physics Institute.

FemtoLine Components

Table of Contents

FEMTOLINE LASER OPTICS	3		
Laser Mirrors	3	Polarization Plane Rotators	29
Low GDD Ultrafast Mirrors	3	Group Velocity Delay Compensation Plates	30
Dual Band Mirrors	5	Crystal Windows	
Broadband Low GDD Ultrafast Mirrors	6	for White Light (Continuum) Generation	31
High Power IBS Coated Laser Mirrors	7	Variable Attenuators	
Enhanced Silver Mirrors	9	for Linearly Polarized Laser Beam	32
Laser Harmonic Separators	11	990-0076 Compact Variable Laser	
Laser Output Couplers	13	Power Attenuator	32
Laser Rear Mirrors	14	990-0077, 990-0078 Compact Variable	
Laser Beamsplitters	16	Laser Power Attenuators	33
Broadband Laser Beamsplitters	18	990-0070 Variable Attenuator	34
Thin Lenses	19	990-0070HBBi70 Variable Broadband Attenuator	35
Anti-Reflective Coated Lens Kits	21	990-0071 Variable Attenuator	36
Thin Film Laser Polarizers	23	990-0072 Variable Attenuator	37
56° Angle of Incidence	23	990-0073 Variable Attenuator	38
70° Angle of Incidence	25	Fixed Ratio Beam Expanders for High Power Lasers	39
45° Angle of Incidence	25		
Quartz Retardation Waveplates	26	FEMTOLINE LASER CRYSTALS	40
Zero Order Optically Contacted Waveplates	26	Ti:Sapphire Laser Line and Harmonics Crystals	40
Zero Order Air-Spaced Waveplates	27	Thin BBO crystals for SHG and THG of	
Zero Order Dual Wavelength Waveplates	27	Ti:Sapphire Laser Wavelength	41
Low Order Waveplates	28	BBO for SHG @ 800 nm	42
Multiple Order Dual Wavelength Waveplates	28	BBO for THG @ 800 nm	43
		Femtokits for third harmonic generation of	
		femtosecond Ti:Sapphire laser	44
		Basic Femtokit FK Series	44
		Extended FemtoKit FKE Series	45
		Thin AgGaS ₂ Crystals for DFG → 2.5-1.3 μm	46
		Yb:KGW and Yb:KYW Crystals	
		Laser Lines and Harmonics	47
		BBO and LBO crystals for	
		Yb:KGW/KYW frequency conversion	48
		SHG LBO crystals	48
		SHG BBO crystals	48

FemtoLine Laser Optics

LASER MIRRORS

Laser mirrors for femtosecond applications are designed to have a broad operating wavelength range and linear phase versus frequency characteristics (group delay dispersion (GDD)). The coating is a single layer dielectric and has no phase shift over the operating wavelength region. High reflectivity mirrors always have higher reflection,

broader operating region and lower pulse distortion for s-polarization than for p-polarization for the same dielectric coating. If possible use the mirrors with s-polarized beam. Our standard mirrors are suitable for fundamental Ti:Sapphire and Yb:KGW or KYW lasers and their doubled, tripled or quadrupled frequencies.

Substrate

Material	UV grade Fused Silica or BK7 glass
S1 surface flatness	$\lambda/10$ at 633 nm
S1 surface quality	20-10 scratch & dig (MIL-PRF-13830B)
S2 surface quality	Commercial polish
Diameter tolerance	+0.00 mm -0.12 mm
Thickness tolerance	± 0.25 mm
Wedge	< 3 min
Chamfer	0.3 mm at 45° typical

Coating

Technology	Electron beam multilayer dielectric
Adhesion and durability	Per MIL-C-675A. Insoluble in lab solvents
Clear aperture	Exceeds central 85% of diameter
Angle of incidence	0 or 45 \pm 3°
Designed for average polarization	$R=(R_s+R_p)/2$
Laser damage threshold	>100 mJ/cm ² , 50 fsec pulse, 50 Hz, 800 nm typical
Coated surface flatness	$\lambda/10$ at 633 nm over clear aperture

LOW GDD ULTRAFAST MIRRORS

Substrate material: BK7 grade A

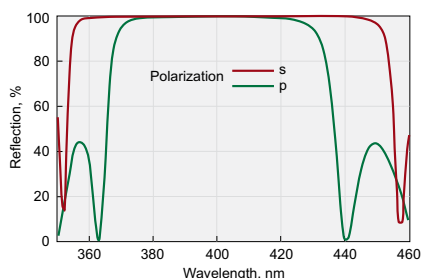

HR > 99.5% @ 380 - 420 nm, AOI = 45°

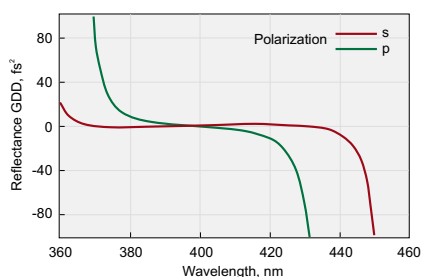

HRsp @ 380 - 420 GDD, AOI = 45°

Related Products

Adapter for Mirror at 45° 840-0115

Find more at EksmaOptics.com

Wavelength, nm	AOI=0°			AOI=45°		
	R, % (s+p)/2	Catalogue number	Price, EUR	R, % (s+p)/2	Catalogue number	Price, EUR

Size - Ø12.7 × 3 mm

380 - 420	99.7	031-0400-i0	63	99.5	031-0400	63
500 - 530	99.7	031-0515-i0	62	99.5	031-0515	62
760 - 840	99.7	031-0800-i0	67	99.5	031-0800	67
1000 - 1060	99.7	031-1030-i0	63	99.5	031-1030	63

Size - Ø12.7 × 6 mm

380 - 420	99.7	031-0400T6-i0	63	99.5	031-0400T6	63
500 - 530	99.7	031-0515T6-i0	62	99.5	031-0515T6	62
760 - 840	99.7	031-0800T6-i0	67	99.5	031-0800T6	67
1000 - 1060	99.7	031-1030T6-i0	63	99.5	031-1030T6	63

Size - Ø25.4 × 6 mm

380 - 420	99.7	032-0400-i0	98	99.5	032-0400	98
500 - 530	99.7	032-0515-i0	81	99.5	032-0515	81
760 - 840	99.7	032-0800-i0	98	99.5	032-0800	94
1000 - 1060	99.7	032-1030-i0	86	99.5	032-1030	83

Size - Ø50.8 × 8 mm

380 - 420	99.7	035-0400-i0	146	99.5	035-0400	146
500 - 530	99.7	035-0515-i0	121	99.5	035-0515	121
760 - 840	99.7	035-0800-i0	153	99.5	035-0800	146
1000 - 1060	99.7	035-1030-i0	127	99.5	035-1030	121

Size - Ø76.2 × 12.7 mm

380 - 420	99.7	037-0400-i0	219	99.5	037-0400	219
500 - 530	99.7	037-0515-i0	204	99.5	037-0515	204
760 - 840	99.7	037-0800-i0	219	99.5	037-0800	219
1000 - 1060	99.7	037-1030-i0	204	99.5	037-1030	204

LOW GDD ULTRAFAST MIRRORS

Substrate material: UV grade Fused Silica

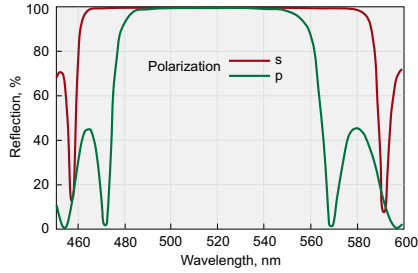

HR>99.5% @ 500-530 nm, AOI=45°

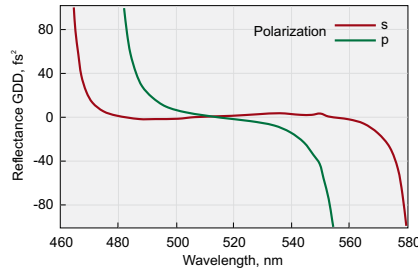

HRsp @ 500-530 GDD, AOI=45°

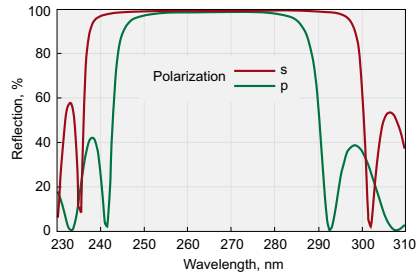

HR>99% @ 257-275 nm, AOI=45°

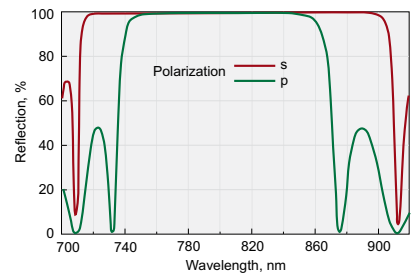

HR>99.5% @ 760-840 nm, AOI=45°

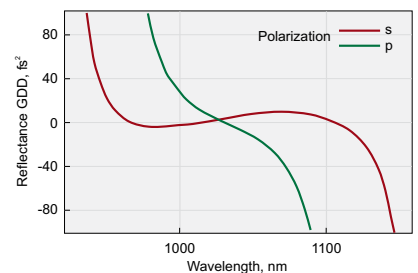

HRsp @ 1000-1060 GDD, AOI=45°

Wavelength, nm	AOI=0°			AOI=45°		
	R, % (s+p)/2	Catalogue number	Price, EUR	R, % (s+p)/2	Catalogue number	Price, EUR

Size – Ø12.7 × 3 mm

257 – 275	99.0	041-0266-i0	78	99.0	041-0266	78
333 – 353	99.7	041-0343-i0	85	99.5	041-0343	85
380 – 420	99.7	041-0400-i0	74	99.5	041-0400	74
500 – 530	99.7	041-0515-i0	68	99.5	041-0515	68
760 – 840	99.7	041-0800-i0	83	99.5	041-0800	83
1000 – 1060	99.7	041-1030-i0	68	99.5	041-1030	68

Size – Ø12.7 × 6 mm

257 – 275	99.0	041-0266T6-i0	78	99.0	041-0266T6	78
333 – 353	99.7	041-0343T6-i0	85	99.5	041-0343T6	85
380 – 420	99.7	041-0400T6-i0	74	99.5	041-0400T6	74
500 – 530	99.7	041-0515T6-i0	68	99.5	041-0515T6	68
760 – 840	99.7	041-0800T6-i0	83	99.5	041-0800T6	83
1000 – 1060	99.7	041-1030T6-i0	68	99.5	041-1030T6	68

Size – Ø25.4 × 6 mm

257 – 275	99.0	042-0266-i0	109	99.0	042-0266	109
333 – 353	99.7	042-0343-i0	118	99.5	042-0343	118
380 – 420	99.7	042-0400-i0	105	99.5	042-0400	105
500 – 530	99.7	042-0515-i0	99	99.5	042-0515	99
760 – 840	99.7	042-0800-i0	112	99.5	042-0800	107
1000 – 1060	99.7	042-1030-i0	104	99.5	042-1030	99
1400 – 1700	99.0	082-1417-i0	231	99.0	082-1417	231
1900 – 2120	99.8	082-1921-i0	231	99.8	082-1921	231

Size – Ø50.8 × 8 mm

257 – 275	99.0	045-0266-i0	228	99.0	045-0266	228
333 – 353	99.7	045-0343-i0	206	99.5	045-0343	206
380 – 420	99.7	045-0400-i0	199	99.5	045-0400	199
500 – 530	99.7	045-0515-i0	186	99.5	045-0515	186
760 – 840	99.7	045-0800-i0	208	99.5	045-0800	199
1000 – 1060	99.7	045-1030-i0	194	99.5	045-1030	186

Size – Ø76.2 × 12.7 mm

257 – 275	99.0	047-0266-i0	380	99.0	047-0266	380
333 – 353	99.7	047-0343-i0	380	99.5	047-0343	380
380 – 420	99.7	047-0400-i0	380	99.5	047-0400	380
500 – 530	99.7	047-0515-i0	380	99.5	047-0515	380
760 – 840	99.7	047-0800-i0	380	99.5	047-0800	380
1000 – 1060	99.7	047-1030-i0	380	99.5	047-1030	380

Recommended for high power laser applications operating in UV region.

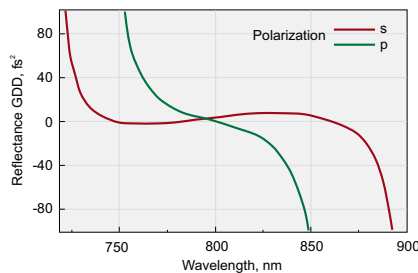

HRsp @ 760-840 GDD, AOI=45°

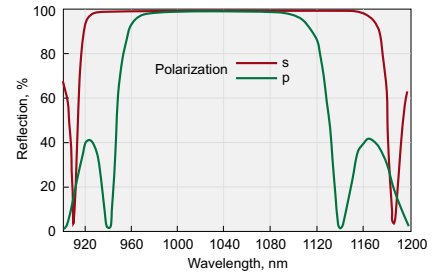

HR>99.5% @ 1000-1060 nm, AOI=45°

DUAL BAND MIRRORS

Substrate

Material	UV grade Fused Silica or BK7 glas
S1 surface flatness	$\lambda/10$ at 633 nm
S1 surface quality	20-10 scratch & dig (MIL-PRF-13830B)
S2 surface quality	Commercial polish
Diameter tolerance	+0.00 mm; -0.12 mm
Thickness tolerance	± 0.25 mm
Wedge	< 3 min
Chamfer	0.3 mm at 45° typical

Coating

Coating	Electron beam multilayer dielectric
Angle of incidence	0 or 45±3°
Designed for average polarization	$R=(R_s+R_p)/2$
Laser damage threshold	>50 mJ/cm², 50 fsec pulse, 50 Hz, 800 nm typical

DUAL BAND MIRRORS

Substrate material: BK7 grade A

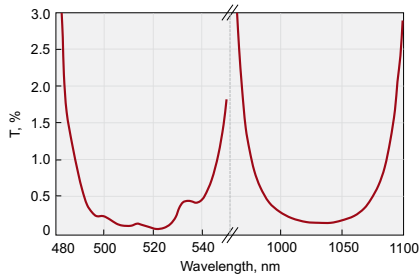

HR>99.5% @ 500-530 nm + 1000-1060 nm, AOI = 45°

Wavelength, nm	AOI=0°			AOI=45°		
	R, % (s+p)/2	Catalogue number	Price, EUR	R, % (s+p)/2	Catalogue number	Price, EUR

Size – Ø12.7 × 3 mm

390-410 + 780-820	99.7	051-4080-i0	94	99.5	051-4080	94
500-530 + 1000-1060	99.7	051-5103-i0	94	99.5	051-5103	94

Size – Ø12.7 × 6 mm

390-410 + 780-820	99.7	051-4080T6-i0	94	99.5	051-4080T6	94
500-530 + 1000-1060	99.7	051-5103T6-i0	94	99.5	051-5103T6	94

Size – Ø25.4 × 6 mm

390-410 + 780-820	99.7	052-4080-i0	113	99.5	052-4080	113
500-530 + 1000-1060	99.7	052-5103-i0	113	99.5	052-5103	113

Size – Ø50.8 × 8 mm

390-410 + 780-820	99.7	055-4080-i0	166	99.5	055-4080	166
500-530 + 1000-1060	99.7	055-5103-i0	166	99.5	055-5103	166

Size – Ø76.2 × 12.7 mm

390-410 + 780-820	99.7	057-4080-i0	250	99.5	057-4080	250
500-530 + 1000-1060	99.7	057-5103-i0	250	99.5	057-5103	250

DUAL BAND MIRRORS

Substrate material: UV grade Fused Silica

Recommended for high power laser applications operating in UV region.

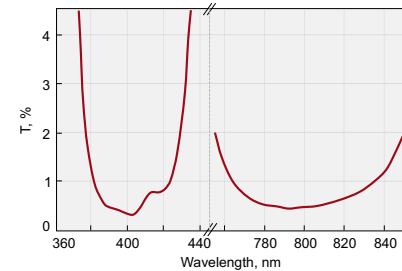

HR>99% @ 400 nm + 800 nm, AOI = 45°

Wavelength, nm	AOI=0°			AOI=45°		
	R, % (s+p)/2	Catalogue number	Price, EUR	R, % (s+p)/2	Catalogue number	Price, EUR

Size – Ø12.7 × 3 mm

390-410 + 780-820	99.7	061-4080-i0	121	99.5	061-4080	121
500-530 + 1000-1060	99.7	061-5103-i0	121	99.5	061-5103	121

Size – Ø12.7 × 6 mm

390-410 + 780-820	99.7	061-4080T6-i0	121	99.5	061-4080T6	121
500-530 + 1000-1060	99.7	061-5103T6-i0	121	99.5	061-5103T6	121

Size – Ø25.4 × 6 mm

390-410 + 780-820	99.7	062-4080-i0	141	99.5	062-4080	141
500-530 + 1000-1060	99.7	062-5103-i0	141	99.5	062-5103	141

Size – Ø50.8 × 8 mm

390-410 + 780-820	99.7	065-4080-i0	235	99.5	065-4080	235
500-530 + 1000-1060	99.7	065-5103-i0	235	99.5	065-5103	235

Size – Ø76.2 × 12.7 mm

390-410 + 780-820	99.7	067-4080-i0	395	99.5	067-4080	395
500-530 + 1000-1060	99.7	067-5103-i0	395	99.5	067-5103	395

BROADBAND LOW GDD ULTRAFAST MIRRORS

Features

- High reflectivity and low group delay dispersion in broad region centered at 800 nm
- $R_s > 99\%$ @ 700 – 930 nm, $|GDDs| < 30 \text{ fs}^2$ @ 700 – 930 nm
- $R_p > 99\%$ @ 730 – 870 nm, $|GDDp| < 30 \text{ fs}^2$ @ 730 – 870 nm
- $R > 99\%$ @ 720 – 880 nm, $|GDD| < 30 \text{ fs}^2$ @ 720 – 880 nm

Specifications

Coating	Hard Dielectric High Reflection
Angle of incidence	0 or $45 \pm 3^\circ$
Designed for average polarization	$R = (R_s + R_p) / 2$
Laser damage threshold	$> 100 \text{ mJ/cm}^2$, 50 fsec pulse, 50 Hz, 800 nm typical

Substrate

Material	UV grade Fused Silica or BK7 glas
S1 surface flatness	$\lambda/10$ at 633 nm
S1 surface quality	20–10 scratch & dig (MIL-PRF-13830B)
S2 surface quality	Commercial polish
Diameter tolerance	+0.00 mm; -0.12 mm
Thickness tolerance	$\pm 0.25 \text{ mm}$
Wedge	$< 3 \text{ min}$
Chamfer	0.3 mm at 45° typical

BROADBAND LOW GDD ULTRAFAST MIRRORS

Wavelength, nm	Diameter, mm	Thickness, mm	AOI = 0°			AOI = 45°		
			R, % (s+p)/2	Catalogue number	Price, EUR	R, % (s+p)/2	Catalogue number	Price, EUR

Substrate material: BK7 grade A

720–880	12.7	3.0	99.0	071-7288-i0	103	99.0	071-7288	103
720–880	12.7	6.0	99.0	071-7288T6-i0	103	99.0	071-7288T6	103
720–880	25.4	6.0	99.0	072-7288-i0	125	99.0	072-7288	125
720–880	38.1	8.0	99.0	074-7288-i0	234	99.0	074-7288	234
720–880	50.8	8.0	99.0	075-7288-i0	264	99.0	075-7288	264
720–880	76.2	12.7	99.0	077-7288-i0	474	99.0	077-7288	474
720–880	101.6	15.0	99.0	078-7288-i0	648	99.0	078-7288	648

Substrate material: UV grade Fused Silica

720–880	12.7	3.0	99.0	081-7288-i0	115	99.0	081-7288	115
720–880	12.7	6.0	99.0	081-7288T6-i0	115	99.0	081-7288T6	115
720–880	25.4	6.0	99.0	082-7288-i0	155	99.0	082-7288	155
720–880	38.1	8.0	99.0	084-7288-i0	270	99.0	084-7288	270
720–880	50.8	8.0	99.0	085-7288-i0	306	99.0	085-7288	306
720–880	76.2	12.7	99.0	087-7288-i0	552	99.0	087-7288	552
720–880	101.6	15.0	99.0	088-7288-i0	734	99.0	088-7288	734

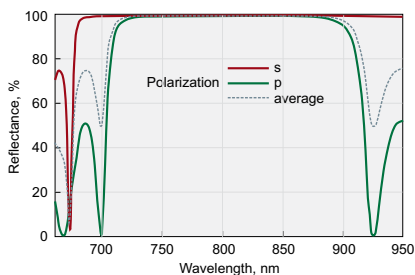

HR > 99% @ 720–880 nm, AOI = 45°

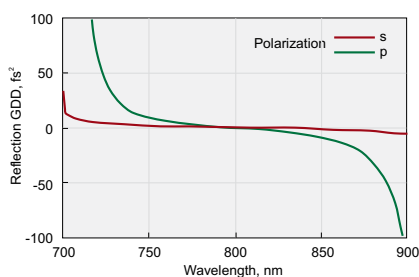

HR > 99% @ 720–880 nm, AOI = 45°

HIGH POWER IBS COATED LASER MIRRORS

Substrate

Material	UV grade fused silica
S1 surface flatness	$\lambda/10$ at 633 nm
S1 surface quality	20 - 10 scratch & dig (MIL-PRF-13830B)
S2 surface quality	Commercial polish
Diameter tolerance	+0.00 mm / -0.12 mm
Thickness tolerance	± 0.25 mm
Wedge	< 3 min
Chamfer	0.3 mm at 45° typical

Coating

Technology	Ion beam sputtering (IBS)
Adhesion and durability	Per MIL-C-675A, Insoluble in lab solvents
Clear aperture	Exceeds central 85% of diameter
Coated surface flatness	$\lambda/8$ at 633 nm over 80% of diameter
Group delay dispersion	< 30 fs ²

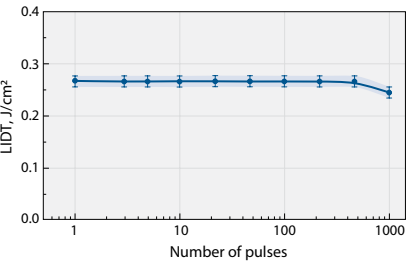

Test conditions:

Wavelength	800 nm
Pulse duration	52.4 fs
Repetition rate	50 Hz
AOI	45°
Polarization	linear P
Beam diameter (1/e ²)	(95.5 ± 0.9) μm

LIDT of High Power Laser Mirrors
@ 720-880 nm, AOI = 45°

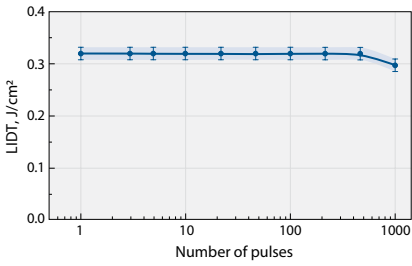

Test conditions:

Wavelength	800 nm
Pulse duration	52.4 fs
Repetition rate	50 Hz
AOI	0°
Polarization	linear
Beam diameter (1/e ²)	(95.5 ± 0.9) μm

LIDT of High Power Laser Mirrors
@ 720-880 nm, AOI = 0°

Design wavelength range – 257 nm. LIDT > 0.3 J/cm², 200 fs pulse, 1 kHz, 257 nm typical.

Wavelength, nm	AOI, deg	R, % (s+p)/2	Ø 12.7 x 6 mm		Ø 25.4 x 6 mm		Ø 50.8 x 12 mm	
			Catalogue number	Price, EUR	Catalogue number	Price, EUR	Catalogue number	Price, EUR
257	45	99.5	041-0257HHR	149	042-0257HHR	190	045-0257HHR	435
257	0	99.5	041-0257HHR-i0	149	042-0257HHR-i0	190	045-0257HHR-i0	435

Design wavelength range – 333-353 nm. LIDT > 0.2 J/cm², 200 fs pulse, 100 Hz, 333-353 nm typical.

Wavelength, nm	AOI, deg	R, % (s+p)/2	Ø 12.7 x 6 mm		Ø 25.4 x 6 mm		Ø 50.8 x 12 mm	
			Catalogue number	Price, EUR	Catalogue number	Price, EUR	Catalogue number	Price, EUR
333 - 353	45	99.8	041-0343HHR	149	042-0343HHR	190	045-0343HHR	435
333 - 353	0	99.8	041-0343HHR-i0	149	042-0343HHR-i0	190	045-0343HHR-i0	435

Design wavelength range – 343 nm. LIDT > 0.4 J/cm², 200 fs pulse, 100 Hz, 343 nm typical.

Wavelength, nm	AOI, deg	R, % (s+p)/2	Ø 12.7 x 6 mm		Ø 25.4 x 6 mm		Ø 50.8 x 12 mm	
			Catalogue number	Price, EUR	Catalogue number	Price, EUR	Catalogue number	Price, EUR
343	45	99.8	041-0343PHR	149	042-0343PHR	198	045-0343PHR	450
343	0	99.8	041-0343PHR-i0	149	042-0343PHR-i0	198	045-0343PHR-i0	450

Design wavelength – 500-530 nm. LIDT > 0.15 J/cm², 50 fs pulse, 100 Hz, 515 nm typical.

Wavelength, nm	AOI, deg	R, % (s+p)/2	Ø 12.7 x 6 mm		Ø 25.4 x 6 mm		Ø 50.8 x 12 mm	
			Catalogue number	Price, EUR	Catalogue number	Price, EUR	Catalogue number	Price, EUR
500 - 530	45	99.9	041-0515T6HHR	83	042-0515HHR	116	045-0515T12HHR	410
500 - 530	0	99.9	041-0515T6HHR-i0	83	042-0515HHR-i0	116	045-0515T12HHR-i0	410

Design wavelength – 760-840 nm. LIDT > 0.2 J/cm², 50 fs pulse, 100 Hz, 800 nm typical.

Wavelength, nm	AOI, deg	R, % (s+p)/2	Ø 12.7 x 6 mm		Ø 25.4 x 6 mm		Ø 50.8 x 12 mm	
			Catalogue number	Price, EUR	Catalogue number	Price, EUR	Catalogue number	Price, EUR
760 - 840	45	99.9	041-0800T6HHR	119	042-0800HHR	143	045-0800T12HHR	440
760 - 840	0	99.9	041-0800T6HHR-i0	119	042-0800HHR-i0	143	045-0800T12HHR-i0	440
760 - 840	0-45	99.9	041-0800T6HHR-i0-45	121	042-0800HHR-i0-45	154	045-0800HHR-i0-45	480

Design wavelength – 760–840 nm. LIDT >0.3 J/cm², 50 fs pulse, 100 Hz, 800 nm typical.

Wavelength, nm	AOI, deg	R, % (s+p)/2	Ø 12.7 x 6 mm		Ø 25.4 x 6 mm		Ø 50.8 x 12 mm	
			Catalogue number	Price, EUR	Catalogue number	Price, EUR	Catalogue number	Price, EUR
760 – 840	45	99.9	041-0800T6UHHR	174	042-0800UHHR	209	045-0800T12UHHR	570
760 – 840	0	99.9	041-0800T6UHHR-i0	174	042-0800UHHR-i0	209	045-0800T12UHHR-i0	570

Design wavelength – 720–880 nm. LIDT >0.15 J/cm², 50 fs pulse, 100 Hz, 800 nm typical.

Wavelength, nm	AOI, deg	R, % (s+p)/2	Ø 12.7 x 6 mm		Ø 25.4 x 6 mm		Ø 50.8 x 12 mm		Ø 76.2 x 15 mm	
			Catalogue number	Price, EUR	Catalogue number	Price, EUR	Catalogue number	Price, EUR	Catalogue number	Price, EUR
720 – 880	45	99.8	081-7288HHR	136	082-7288HHR	174	085-7288T12HHR	588	087-7288HHR	738
720 – 880	0	99.9	081-7288HHR-i0	136	082-7288HHR-i0	174	085-7288T12HHR-i0	588	087-7288HHR-i0	738

Design wavelength – 1000–1060 nm. LIDT >0.6 J/cm², 190 fs pulse, 10 kHz, 1030 nm typical.

Wavelength, nm	AOI, deg	R, % (s+p)/2	Ø 12.7 x 6 mm		Ø 25.4 x 6 mm		Ø 50.8 x 12 mm	
			Catalogue number	Price, EUR	Catalogue number	Price, EUR	Catalogue number	Price, EUR
1000 – 1060	45	99.9	041-1030T6HHR	83	042-1030HHR	116	045-1030T12HHR	410
1000 – 1060	0	99.9	041-1030T6HHR-i0	83	042-1030HHR-i0	116	045-1030T12HHR-i0	410

Design wavelength – 930–1130 nm. LIDT >0.3 J/cm², 200 fs pulse, 100 Hz, 1030 nm typical.

Wavelength, nm	AOI, deg	R, % (s+p)/2	Ø 12.7 x 6 mm		Ø 25.4 x 6 mm		Ø 50.8 x 12 mm		Ø 76.2 x 15 mm	
			Catalogue number	Price, EUR	Catalogue number	Price, EUR	Catalogue number	Price, EUR	Catalogue number	Price, EUR
930 – 1130	45	99.8	081-9311HHR	140	082-9311HHR	195	085-9311HHR	590	087-9311HHR	1350
930 – 1130	0	99.8	081-9311HHR-i0	140	082-9311HHR-i0	195	085-9311HHR-i0	590	087-9311HHR-i0	1350

Design wavelength – 960 – 1100 nm. LIDT >0.4 J/cm², 200 fs pulse, 100 Hz, 1030 nm typical.

Wavelength, nm	AOI, deg	R, % (s+p)/2	Ø 12.7 x 6 mm		Ø 25.4 x 6 mm		Ø 50.8 x 12 mm		Ø 76.2 x 15 mm	
			Catalogue number	Price, EUR	Catalogue number	Price, EUR	Catalogue number	Price, EUR	Catalogue number	Price, EUR
960 – 1100	45	99.9	081-9611HHR	140	082-9611HHR	195	085-9611HHR	590	087-9611HHR	1350
960 – 1100	0	99.9	081-9611HHR-i0	140	082-9611HHR-i0	195	085-9611HHR-i0	590	087-9611HHR-i0	1350

Design wavelength range – 1400–1700 nm. LIDT > 0.3 J/cm², 50 fs pulse, 100 Hz, 1550 nm typical.

Wavelength, nm	AOI, deg	R, % (s+p)/2	Ø 12.7 x 6 mm		Ø 25.4 x 6 mm		Ø 50.8 x 12 mm	
			Catalogue number	Price, EUR	Catalogue number	Price, EUR	Catalogue number	Price, EUR
1400 – 1700	45	99.8	081-1417	158	082-1417	231	085-1417	570
1400 – 1700	0	99.8	081-1417-i0	158	082-1417-i0	231	085-1417-i0	570

Design wavelength range – 1900–2120 nm. LIDT > 0.4 J/cm², 50 fs pulse, 100 Hz, 2000 nm typical.

Wavelength, nm	AOI, deg	R, % (s+p)/2	Ø 12.7 x 6 mm		Ø 25.4 x 6 mm		Ø 50.8 x 12 mm	
			Catalogue number	Price, EUR	Catalogue number	Price, EUR	Catalogue number	Price, EUR
1900 – 2120	45	99.8	081-1921	168	082-1921	231	085-1921	595
1900 – 2120	0	99.8	081-1921-i0	168	082-1921-i0	231	085-1921-i0	595

ENHANCED SILVER MIRRORS

Features

- LIDT – 0.25 J/cm² at 800 nm, 50 Hz, 94 fs pulses
- Round, square, flat or spherical mirrors available
- Reflectivity R>98.5% @ 600 – 1100 nm, R>99% @ 700 – 900 nm
- Operating angle of incidence from 0° to 45°
- Group delay dispersion < |5 fs²|

Enhanced silver mirrors are designed for applications with femtosecond lasers. These mirrors feature high reflectivity R>98.5% in the wavelength range from 600 nm to 1100 nm and R>99% @ 700 – 900 nm. Mirrors are relatively insensitive to angle of incidence and can be used in applications with AOI ranging from 0° to 45°.

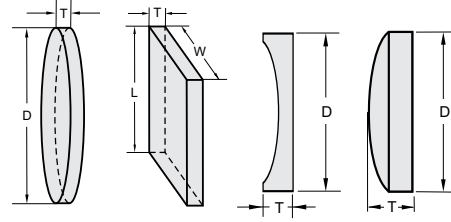

Drawings of flat round, flat rectangular and spherical mirrors

Flat Rectangular Mirrors. Substrate type: plano-plano

Width W, mm	Length L, mm	Thickness T, mm	Substrate material	Catalogue number	Price, EUR
15.0	20.0	6	UVFS	091-3325F	77
20.0	30.0	6	UVFS	092-3325F	101
25.4	25.4	6	UVFS	093-3325F	99
25.4	50.8	10	UVFS	094-3325F	149
50.8	50.8	10	UVFS	095-3325F	193

Flat Round Mirrors. Substrate type: plano-plano

Diameter D, mm	Thickness T, mm	Substrate material	Catalogue number	Price, EUR
Ø12.7	3	UVFS	091-3025F	62
Ø12.7	6	UVFS	091-3025FT6	62
Ø25.4	6	UVFS	092-3025F	94
Ø50.8	8	UVFS	095-3025F	178
Ø76.2	12.7	UVFS	097-3025F	435
Ø101.6	15	UVFS	098-3025F	638

Spherical Mirrors. Diameter, D = 12.7 mm. Thickness (edge for plano-concave, center for plano-convex), T = 6.0 mm

Radius, mm	Substrate type	Substrate material	Catalogue number	Price, EUR
-50	Plano-concave	UVFS	091-3125FR-50	95
-75	Plano-concave	UVFS	091-3125FR-75	95
-100	Plano-concave	UVFS	091-3125FR-100	95
-150	Plano-concave	UVFS	091-3125FR-150	95
-200	Plano-concave	UVFS	091-3125FR-200	95
-250	Plano-concave	UVFS	091-3125FR-250	95
-300	Plano-concave	UVFS	091-3125FR-300	95
-400	Plano-concave	UVFS	091-3125FR-400	95
-500	Plano-concave	UVFS	091-3125FR-500	95
-1000	Plano-concave	UVFS	091-3125FR-1000	95
-1500	Plano-concave	UVFS	091-3125FR-1500	95
-2000	Plano-concave	UVFS	091-3125FR-2000	95
+50	Plano-convex	UVFS	091-3225FR+50	98
+100	Plano-convex	UVFS	091-3225FR+100	98
+150	Plano-convex	UVFS	091-3225FR+150	98
+200	Plano-convex	UVFS	091-3225FR+200	98
+300	Plano-convex	UVFS	091-3225FR+300	98
+400	Plano-convex	UVFS	091-3225FR+400	98
+500	Plano-convex	UVFS	091-3225FR+500	98

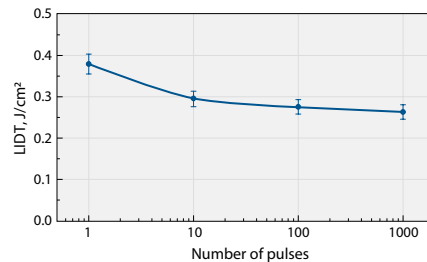

Test conditions:

Wavelength	800 nm
Pulse duration	99.9 fs
Repetition rate	100 Hz
AOI	45°
Polarization	linear P
Beam diameter (1/e ²)	(143 ± 2.3) μm

LIDT of enhanced silver mirrors, AOI=45° @ 800 nm, 100 fs, 100 Hz

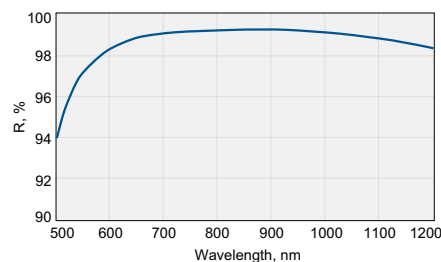

Reflectivity of enhanced silver mirrors, AOI=0°

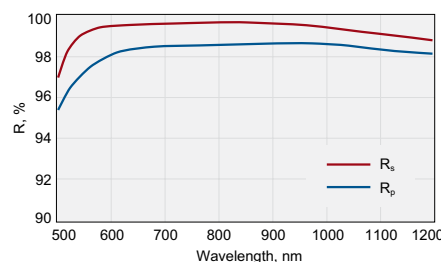

Reflectivity of enhanced silver mirrors, AOI=45°

Spherical Mirrors. Diameter, D = 25.4 mm. Thickness (edge for plano-concave, center for plano-convex), T = 6.0 mm

Radius, mm	Substrate type	Substrate material	Catalogue number	Price, EUR
-50	Plano-concave	UVFS	092-3125FR-50	149
-75	Plano-concave	UVFS	092-3125FR-75	149
-100	Plano-concave	UVFS	092-3125FR-100	149
-150	Plano-concave	UVFS	092-3125FR-150	149
-200	Plano-concave	UVFS	092-3125FR-200	149
-250	Plano-concave	UVFS	092-3125FR-250	149
-300	Plano-concave	UVFS	092-3125FR-300	149
-400	Plano-concave	UVFS	092-3125FR-400	149
-500	Plano-concave	UVFS	092-3125FR-500	149
-600	Plano-concave	UVFS	092-3125FR-600	149
-700	Plano-concave	UVFS	092-3125FR-700	149
-750	Plano-concave	UVFS	092-3125FR-750	149
-800	Plano-concave	UVFS	092-3125FR-800	149
-1000	Plano-concave	UVFS	092-3125FR-1000	149
-1500	Plano-concave	UVFS	092-3125FR-1500	149
-2000	Plano-concave	UVFS	092-3125FR-2000	149
-2500	Plano-concave	UVFS	092-3125FR-2500	149
-3000	Plano-concave	UVFS	092-3125FR-3000	149
-4000	Plano-concave	UVFS	092-3125FR-4000	149
-5000	Plano-concave	UVFS	092-3125FR-5000	149
-6000	Plano-concave	UVFS	092-3125FR-6000	149
-8000	Plano-concave	UVFS	092-3125FR-8000	149
+50	Plano-convex	UVFS	092-3225FR+50	154
+100	Plano-convex	UVFS	092-3225FR+100	154
+150	Plano-convex	UVFS	092-3225FR+150	154
+200	Plano-convex	UVFS	092-3225FR+200	154
+300	Plano-convex	UVFS	092-3225FR+300	154
+400	Plano-convex	UVFS	092-3225FR+400	154
+500	Plano-convex	UVFS	092-3225FR+500	154
+600	Plano-convex	UVFS	092-3225FR+600	154
+800	Plano-convex	UVFS	092-3225FR+800	154
+1000	Plano-convex	UVFS	092-3225FR+1000	154
+1500	Plano-convex	UVFS	092-3225FR+1500	154
+2000	Plano-convex	UVFS	092-3225FR+2000	154
+4000	Plano-convex	UVFS	092-3225FR+4000	154
+5000	Plano-convex	UVFS	092-3225FR+5000	154

Spherical Mirrors. Diameter, D = 76.2 mm. Thickness (edge for plano-concave, center for plano-convex), T = 12.7 mm

Radius, mm	Substrate type	Substrate material	Catalogue number	Price, EUR
-200	Plano-concave	UVFS	097-3125FR-200	528
-300	Plano-concave	UVFS	097-3125FR-300	528
-400	Plano-concave	UVFS	097-3125FR-400	528
-500	Plano-concave	UVFS	097-3125FR-500	528
-600	Plano-concave	UVFS	097-3125FR-600	528
-800	Plano-concave	UVFS	097-3125FR-800	528
-1000	Plano-concave	UVFS	097-3125FR-1000	528
-2000	Plano-concave	UVFS	097-3125FR-2000	528
-3000	Plano-concave	UVFS	097-3125FR-3000	528

Spherical Mirrors. Diameter, D = 50.8 mm. Thickness (edge for plano-concave, center for plano-convex), T = 10.0 mm

Radius, mm	Substrate type	Substrate material	Catalogue number	Price, EUR
-100	Plano-concave	UVFS	095-3125FR-100	270
-150	Plano-concave	UVFS	095-3125FR-150	270
-200	Plano-concave	UVFS	095-3125FR-200	270
-250	Plano-concave	UVFS	095-3125FR-250	270
-300	Plano-concave	UVFS	095-3125FR-300	270
-400	Plano-concave	UVFS	095-3125FR-400	270
-500	Plano-concave	UVFS	095-3125FR-500	270
-600	Plano-concave	UVFS	095-3125FR-600	270
-800	Plano-concave	UVFS	095-3125FR-800	270
-1000	Plano-concave	UVFS	095-3125FR-1000	270
-1500	Plano-concave	UVFS	095-3125FR-1500	270
-2000	Plano-concave	UVFS	095-3125FR-2000	270
-2500	Plano-concave	UVFS	095-3125FR-2500	270
-3000	Plano-concave	UVFS	095-3125FR-3000	270
-4000	Plano-concave	UVFS	095-3125FR-4000	270
-5000	Plano-concave	UVFS	095-3125FR-5000	270
-6000	Plano-concave	UVFS	095-3125FR-6000	270
-8000	Plano-concave	UVFS	095-3125FR-8000	270
-10000	Plano-concave	UVFS	095-3125FR-10000	270
+100	Plano-convex	UVFS	095-3225FR+100	281
+150	Plano-convex	UVFS	095-3225FR+150	281
+200	Plano-convex	UVFS	095-3225FR+200	281
+300	Plano-convex	UVFS	095-3225FR+300	281
+400	Plano-convex	UVFS	095-3225FR+400	281
+500	Plano-convex	UVFS	095-3225FR+500	281
+600	Plano-convex	UVFS	095-3225FR+600	281
+800	Plano-convex	UVFS	095-3225FR+800	281
+1000	Plano-convex	UVFS	095-3225FR+1000	281
+1500	Plano-convex	UVFS	095-3225FR+1500	281
+2000	Plano-convex	UVFS	095-3225FR+2000	281

Spherical Mirrors. Diameter, D = 101.6 mm. Thickness (edge for plano-concave, center for plano-convex), T = 15.0 mm

Radius, mm	Substrate type	Substrate material	Catalogue number	Price, EUR
-300	Plano-concave	UVFS	098-3125FR-300	825
-400	Plano-concave	UVFS	098-3125FR-400	825
-500	Plano-concave	UVFS	098-3125FR-500	825
-600	Plano-concave	UVFS	098-3125FR-600	825
-800	Plano-concave	UVFS	098-3125FR-800	825
-1000	Plano-concave	UVFS	098-3125FR-1000	825
-2000	Plano-concave	UVFS	098-3125FR-2000	825
-3000	Plano-concave	UVFS	098-3125FR-3000	825

LASER HARMONIC SEPARATORS

Features

- Offered on Ø 0.5 or 1 inch UV FS substrates with surface flatness $\lambda/10$

Harmonic separators are dichroic beamsplitters that reflect one wavelength and transmit others. Reflectance is better than 99.5% for the wavelength of interest and transmittance is at least 90% for the rejected wavelengths. The rear surface of harmonic separators is antireflection coated.

If possible use shorter wavelength for reflection and longer wavelengths for transmission in order to have higher reflection/transmission coefficients.

Substrate

Material	UV grade Fused Silica
S1 surface flatness	$\lambda/10$ typical at 633 nm
S1 surface quality	20-10 scratch & dig (MIL-PRF-13830B)
S2 surface flatness	$\lambda/10$ typical at 633 nm
S2 surface quality	20-10 scratch & dig (MIL-PRF-13830B)
Diameter tolerance	+0.00 mm; -0.12 mm
Thickness tolerance	± 0.25 mm
Parallelism	< 30 arcsec
Chamfer	0.3 mm at 45° typical

LASER HARMONIC SEPARATORS WITH HIGH TRANSMISSION

Coating

Technology	Ion beam sputtering	
Adhesion and durability	Per MIL-C-675A. Insoluble in lab solvents	
Clear aperture	Exceeds central 85% of diameter	
Coated surface flatness	$\lambda/8$ at 633 nm over 80% of diameter	
Transmitted wavefront distortion (TWD)	$\lambda/10$ over clear aperture	
Back side antireflection coated	AOI 45°	$R < 0.5\%$, (s+p)/2
	AOI 0°	$R < 0.2\%$ (broadband) $R < 0.1\%$ (laser line)
Laser Damage Threshold	343 nm	> 0.4 J/cm ² , 200 fs, 100 Hz
	400 nm	> 0.1 J/cm ² , 50 fs, 100 Hz
	515 nm	> 0.15 J/cm ² , 50 fs, 100 Hz
	800 nm	> 0.2 J/cm ² , 50 fs, 100 Hz
	1030 nm	> 0.3 J/cm ² , 50 fs, 100 Hz

Reflected wavelength, nm	Reflection	Transmission	12.7 × 3 mm		25.4 × 6 mm		50.8 × 8 mm	
			Catalogue number	Price, EUR	Catalogue number	Price, EUR	Catalogue number	Price, EUR

AOI = 0 deg. Substrate material: UV grade Fused Silica

257	R _{sp} >99.0%	T _{sp} >98% @ 515 nm + T _{sp} >98% @ 1030 nm	041-2530PHT	219	042-2530PHT	280	045-2530PHT	505
343	R _{sp} >99.5%	T _{sp} >98% @ 515 nm + T _{sp} >99% @ 1030 nm	041-3530PHT	213	042-3530PHT	270	045-3530PHT	490
380 – 420	R _{sp} >99.9%	T _{sp} >99% @ 720 – 880 nm	-	-	042-4800HT	270	045-4800HT	490
505 – 525	R _{sp} >99.9%	T _{sp} >99% @ 1010 – 1050 nm	041-5130HT	196	042-5130HT	247	045-5130HT	450
760 – 840	R _{sp} >99.9%	T _{ave} >95% @ 380 – 420 nm	-	-	042-0840HT	282	045-0840HT	510
1015 – 1045	R _{sp} >99.9%	T _{sp} >98% @ 510 – 520 nm	041-6510HT	201	042-6510HT	253	045-6510HT	470

AOI = 45 deg. Substrate material: UV grade Fused Silica

257	R _{sp} >99.0%	T _{sp} >98% @ 515 nm + T _{sp} >98% @ 1030 nm	041-2535PHT	219	042-2535PHT	280	045-2535PHT	505
343	R _{sp} >99.5%	T _{sp} >98% @ 515 nm + T _{sp} >99% @ 1030 nm	041-3535PHT	213	042-3535PHT	270	045-3535PHT	490
380 – 420	R _{sp} >99.9%	T _{sp} >99% @ 720 – 880 nm	-	-	042-4805HT	270	045-4805HT	490
505 – 525	R _{sp} >99.9%	T _{sp} >99% @ 1010 – 1050 nm	041-5135HT	196	042-5135HT	247	045-5135HT	450
760 – 840	R _{sp} >99.9%	T _{ave} >95% @ 380 – 420 nm	-	-	042-0845HT	282	045-0845HT	510
1015 – 1045	R _{sp} >99.9%	T _{sp} >98% @ 510 – 520 nm	041-6515HT	201	042-6515HT	253	045-6515HT	470

STANDARD LASER HARMONIC SEPARATORS

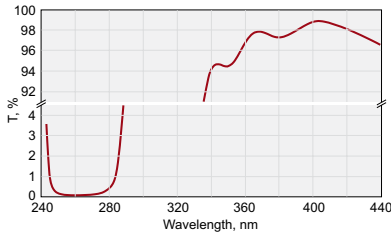

042-2405. HR>99.5% @ 257-275 nm + HT>95% @ 390-410 nm, AOI=45°

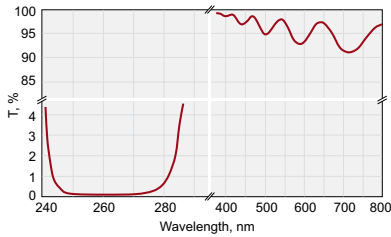

042-2485. HR>99.5% @ 257-275 nm + HT>90% @ 400+800 nm, AOI=45°

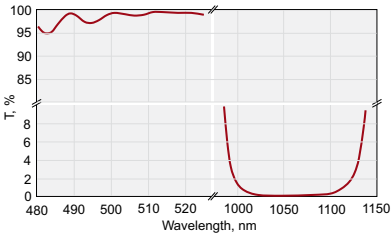

042-6515. HR>99.5% @ 1030 nm + HT>93% @ 515 nm, AOI=45°

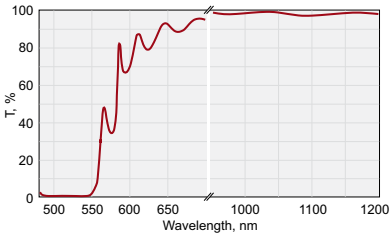

042-5135. HR>99.5% @ 500-530 nm + HT>95% @ 1000-1060 nm, AOI=45°

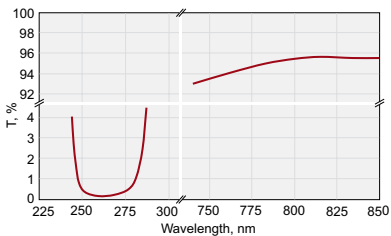

042-2805. HR>99.5% @ 257-275 nm + HT>95% @ 780-820, AOI=45°

Coating

Technology	Electron beam multilayer dielectric
Adhesion and Durability	Per MIL-C-675A. Insoluble in lab solvents
Clear Aperture	Exceeds central 85% of diameter
Coated Surface Flatness	$\lambda/10$ at 633 nm over clear aperture
Back side antireflection coated	AOI 45°, R<0.5% AOI 0°, R<0.25%
Laser Damage Threshold	>100 mJ/cm ² , 50 fsec pulse, 50 Hz, 800 nm typical

Reflected wavelength, nm, R > 99.5%	Transmitted wavelength, nm	Transmission, %	Ø12.7x3 mm		Ø25.4x3 mm		Ø50.8x8 mm	
			Catalogue number	Price, EUR	Catalogue number	Price, EUR	Catalogue number	Price, EUR

AOI = 0 deg. Substrate material: UV grade Fused Silica

257 – 275	780 – 820	>95	041-2800	167	042-2800	201	045-2800	305
257 – 275	390 – 410	>95	041-2400	167	042-2400	201	045-2400	305
257 – 275	400 + 800	>90	041-2480	190	042-2480	224	045-2480	339
390 – 410	780 – 820	>95	041-4800	167	042-4800	201	045-4800	305
800	400	>93	041-0840	161	042-0840	196	045-0840	293
333 – 353	1000 – 1060	>95	041-3130	155	042-3130	190	045-3130	282
333 – 353	500 – 530	>95	041-3450	155	042-3450	190	045-3450	282
333 – 353	515 + 1030	>90	041-3530	178	042-3530	213	045-3530	316
500 – 530	1000 – 1060	>95	041-5130	155	042-5130	190	045-5130	282
1030	515	>93	041-6510	161	042-6510	196	045-6510	293

AOI = 45 deg. Substrate material: UV grade Fused Silica

257 – 275	780 – 820	>95	041-2805	167	042-2805	201	045-2805	305
257 – 275	390 – 410	>95	041-2405	167	042-2405	201	045-2405	305
257 – 275	400 + 800	>90	041-2485	190	042-2485	224	045-2485	339
390 – 410	780 – 820	>95	041-4805	167	042-4805	201	045-4805	305
800	400	>93	041-0845	161	042-0845	196	045-0845	293
333 – 353	1000 – 1060	>95	041-3135	155	042-3135	190	045-3135	282
333 – 353	500 – 530	>95	041-3455	155	042-3455	190	045-3455	282
333 – 353	515 + 1030	>90	041-3535	178	042-3535	213	045-3535	316
500 – 530	1000 – 1060	>95	041-5135	155	042-5135	190	045-5135	282
1030	515	>93	041-6515	161	042-6515	196	045-6515	293

Related Products

Pellin-Broca Prisms.

Find more at EksmaOptics.com

Adapter for Beamsplitter at 45° 840-0116

Find more at EksmaOptics.com

Kinematic Mirror Mount 840-0032, 840-0033

Find more at EksmaOptics.com



LASER OUTPUT COUPLERS

Features

- Low Group Delay Dispersion

An output coupler is a partially reflecting dielectric mirror used in a laser cavity. It transmits a part of the circulating intracavity power for generating a useful output from the laser.

A low transmission output coupler leads to low laser threshold and possibly to poor laser efficiency if the losses due to output coupling do not dominate other parasitic losses in the laser cavity. The output coupler transmission is often chosen to maximize the output power, although its optimum value may be lower or higher if there are other design purposes (minimizing intracavity intensities or suppressing Q-switching instabilities in a passively mode-locked laser).

The standard substrates are parallel within 30 arcsec. If you need wedged substrates, please, choose from chapter Wedge Prisms.

Coating

Technology	Electron beam multilayer dielectric
Adhesion and durability	Per MIL-C-675A. Insoluble in lab solvents
Clear aperture	Exceeds central 85% of diameter
Angle of incidence	0 – 8°
Parallelism	30 arcsec
Back side antireflection coated	R < 0.25%
Laser damage threshold	>100 mJ/cm ² , 50 fsec pulse, 50 Hz, 800 nm typical

Substrate

Material	UV grade Fused Silica
S1 surface flatness	$\lambda/10$ typical at 633 nm
S1 surface quality	20 – 10 scratch & dig (MIL-PRF-13830B)
S2 surface flatness	$\lambda/10$ typical at 633 nm
S2 surface quality	20 – 10 scratch & dig (MIL-PRF-13830B)
Diameter tolerance	+0.00 mm; -0.12 mm
Thickness tolerance	± 0.25 mm
Parallelism	< 30 arcsec
Chamfer	0.3 mm at 45° typical

Wavelength, nm	Reflection, %	Transmission, %	Ø12.7x3 mm		Ø25.4x6 mm		Ø50.8x8 mm	
			Catalogue number	Price, EUR	Catalogue number	Price, EUR	Catalogue number	Price, EUR

Substrate material: UV grade Fused Silica

1030	50±3	50±3	041-0150	121	042-0150	144	045-0150	236
1030	60±3	40±3	041-0160	121	042-0160	144	045-0160	236
1030	65±3	35±3	041-0165	121	042-0165	144	045-0165	236
1030	70±3	30±3	041-0170	121	042-0170	144	045-0170	236
1030	75±3	25±3	041-0175	121	042-0175	144	045-0175	236
1030	80±3	20±3	041-0180	121	042-0180	144	045-0180	236
1030	85±3	15±3	041-0185	121	042-0185	144	045-0185	236
1030	90±2	10±2	041-0190	129	042-0190	152	045-0190	253
1030	95±2	5±2	041-0195	129	042-0195	152	045-0195	253
1030	97±1	3±1	041-0197	137	042-0197	160	045-0197	282
1030	98±1	2±1	041-0198	137	042-0198	160	045-0198	282
1030	99.0±0.5	1.0±0.5	041-0199	145	042-0199	168	045-0199	293
800	50±3	50±3	041-1150	121	042-1150	144	045-1150	236
800	60±3	40±3	041-1160	121	042-1160	144	045-1160	236
800	65±3	35±3	041-1165	121	042-1165	144	045-1165	236
800	70±3	30±3	041-1170	121	042-1170	144	045-1170	236
800	75±3	25±3	041-1175	121	042-1175	144	045-1175	236
800	80±3	20±3	041-1180	121	042-1180	144	045-1180	236
800	85±3	15±3	041-1185	121	042-1185	144	045-1185	236
800	90±2	10±2	041-1190	129	042-1190	152	045-1190	253
800	95±2	5±2	041-1195	129	042-1195	152	045-1195	253
800	97±1	3±1	041-1197	137	042-1197	160	045-1197	282
800	98±1	2±1	041-1198	137	042-1198	160	045-1198	282
800	99.0±0.5	1.0±0.5	041-1199	145	042-1199	168	045-1199	293

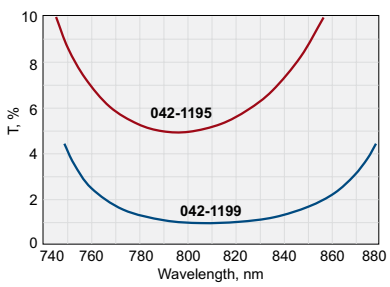

042-1199. PR = 99±0.5% @ 800 nm, T = 1±0.5%
042-1195. PR = 95±2% @ 800 nm, T = 5±2%

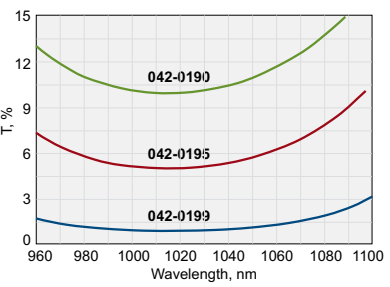

042-0199. PR = 99±0.5% @ 1030 nm, T = 1±0.5%
042-0195. PR = 95±2% @ 1030 nm, T = 5±2%
042-0190. PR = 90±2% @ 1030 nm, T = 10±2%

Related Products

Uncoated Elliptical Mirrors
 Find more at EksmaOptics.com

Kinematic Mirror Mount
840-0032, 840-0033
 Find more at EksmaOptics.com



LASER REAR MIRRORS

High reflectivity ($R > 99.8\%$) dielectric coatings with high laser damage threshold are applied on laser rear mirrors. UV FS substrates are recommended for high power laser applications.

Back side can be AR coated to avoid back reflection from second surface on request.

Coating

Technology	Electron beam multilayer dielectric
Adhesion and Durability	Per MIL-C-675A. Insoluble in lab solvents
Clear Aperture	Exceeds central 85% of diameter
Angle of Incidence	0 – 8° (normal)
Coating	Hard dielectric high reflection: R>99.7% at 800 nm and 1030 nm R>99% at 720 – 880 nm
Laser Damage Threshold	>100 mJ/cm ² , 50 fsec pulse, 50 Hz, 800 nm typical

Substrate

Material	UV grade Fused Silica or BK7 glass
S1 Surface Flatness	$\lambda/10$ at 633 nm
S1 Surface Quality	20 -10 scratch & dig (MIL-PRF-13830B)
S2 Surface Quality	Commercial polish
Diameter Tolerance	+0.00 mm; -0.12 mm
Thickness Tolerance	± 0.25
Chamfer	0.3 mm at 45° typical

Wavelength, nm	Substrate type	Radius, mm	Substrate material BK7				Substrate material UVFS			
			Ø25.4 × 6 mm		Ø50.8 × 10 mm		Ø25.4 × 6 mm		Ø50.8 × 10 mm	
			Catalogue number	Price, EUR	Catalogue number	Price, EUR	Catalogue number	Price, EUR	Catalogue number	Price, EUR
1030±30	Plano-plano	-∞	032-1030-i0	86	035-1030-i0 *	127	042-1030-i0	104	045-1030-i0 *	194
1030±30	Plano-concave	-50	012-8005	114	015-8005	167	022-8005	137	025-8005	240
1030±30	Plano-concave	-100	012-8010	114	015-8010	167	022-8010	137	025-8010	240
1030±30	Plano-concave	-150	012-8015	114	015-8015	167	022-8015	137	025-8015	240
1030±30	Plano-concave	-200	012-8020	114	015-8020	167	022-8020	137	025-8020	240
1030±30	Plano-concave	-250	012-8025	114	015-8025	167	022-8025	137	025-8025	240
1030±30	Plano-concave	-500	012-8050	114	015-8050	167	022-8050	137	025-8050	240
1030±30	Plano-concave	-1000	012-8100	114	015-8100	167	022-8100	137	025-8100	240
1030±30	Plano-concave	-2000	012-8200	114	015-8200	167	022-8200	137	025-8200	240
1030±30	Plano-concave	-2500	012-8250	114	015-8250	167	022-8250	137	025-8250	240
1030±30	Plano-concave	-4000	012-8400	114	015-8400	167	022-8400	137	025-8400	240
1030±30	Plano-concave	-5000	012-8500	114	015-8500	167	022-8500	137	025-8500	240
1030±30	Plano-convex	+100	012-9010	118	015-9010	178	022-9010	141	025-9010	252
1030±30	Plano-convex	+200	012-9020	118	015-9020	178	022-9020	141	025-9020	252
1030±30	Plano-convex	+500	012-9050	118	015-9050	178	022-9050	141	025-9050	252
1030±30	Plano-convex	+1000	012-9100	118	015-9100	178	022-9100	141	025-9100	252
1030±30	Plano-convex	+2000	012-9200	118	015-9200	178	022-9200	141	025-9200	252
1030±30	Plano-convex	+4000	012-9400	118	015-9400	178	022-9400	141	025-9400	252

* Thickness of plano-plano rear mirrors of Ø50.8 is 8 mm.

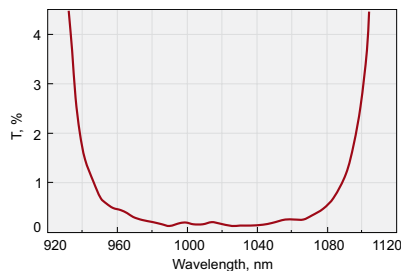

HR>99.7% @ 1030±30 nm, AOI=0°

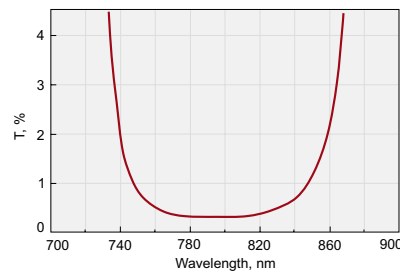

HR>99.7% @ 800±20 nm, AOI=0°

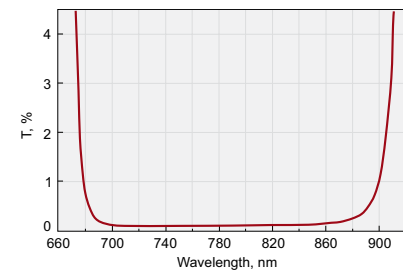

HR>99.0% @ 720 – 880 nm, AOI=0°

Wavelength, nm	Substrate type	Radius, mm	Substrate material BK7				Substrate material UVFS			
			Ø25.4 × 6 mm		Ø50.8 × 10 mm		Ø25.4 × 6 mm		Ø50.8 × 10 mm	
			Catalogue number	Price, EUR	Catalogue number	Price, EUR	Catalogue number	Price, EUR	Catalogue number	Price, EUR
800±30	Plano-plano	-∞	032-0800-i0	98	035-0800-i0 *	153	042-0800-i0	112	045-0800-i0 *	208
800±30	Plano-concave	-50	062-8005	114	065-8005	167	082-8005	137	085-8005	240
800±30	Plano-concave	-100	062-8010	114	065-8010	167	082-8010	137	085-8010	240
800±30	Plano-concave	-150	062-8015	114	065-8015	167	082-8015	137	085-8015	240
800±30	Plano-concave	-200	062-8020	114	065-8020	167	082-8020	137	085-8020	240
800±30	Plano-concave	-250	062-8025	114	065-8025	167	082-8025	137	085-8025	240
800±30	Plano-concave	-500	062-8050	114	065-8050	167	082-8050	137	085-8050	240
800±30	Plano-concave	-1000	062-8100	114	065-8100	167	082-8100	137	085-8100	240
800±30	Plano-concave	-2000	062-8200	114	065-8200	167	082-8200	137	085-8200	240
800±30	Plano-concave	-2500	062-8250	114	065-8250	167	082-8250	137	085-8250	240
800±30	Plano-concave	-4000	062-8400	114	065-8400	167	082-8400	137	085-8400	240
800±30	Plano-concave	-5000	062-8500	114	065-8500	167	082-8500	137	085-8500	240
800±30	Plano-convex	+100	062-9010	118	065-9010	178	082-9010	141	085-9010	252
800±30	Plano-convex	+200	062-9020	118	065-9020	178	082-9020	141	085-9020	252
800±30	Plano-convex	+500	062-9050	118	065-9050	178	082-9050	141	085-9050	252
800±30	Plano-convex	+1000	062-9100	118	065-9100	178	082-9100	141	085-9100	252
800±30	Plano-convex	+2000	062-9200	118	065-9200	178	082-9200	141	085-9200	252
800±30	Plano-convex	+4000	062-9400	118	065-9400	178	082-9400	141	085-9400	252

* Thickness of plano-plano rear mirrors of Ø50.8 is 8 mm.

Wavelength, nm	Substrate type	Radius, mm	Substrate material BK7				Substrate material UVFS			
			Ø25.4 × 6 mm		Ø50.8 × 10 mm		Ø25.4 × 6 mm		Ø50.8 × 10 mm	
			Catalogue number	Price, EUR	Catalogue number	Price, EUR	Catalogue number	Price, EUR	Catalogue number	Price, EUR
720 - 880	Plano-plano	-∞	072-7288-i0	120	075-7288-i0 *	253	082-7288-i0	148	085-7288-i0 *	293
720 - 880	Plano-concave	-50	062-8005B	147	065-8005B	282	082-8005B	176	085-8005B	322
720 - 880	Plano-concave	-100	062-8010B	147	065-8010B	282	082-8010B	176	085-8010B	322
720 - 880	Plano-concave	-150	062-8015B	147	065-8015B	282	082-8015B	176	085-8015B	322
720 - 880	Plano-concave	-200	062-8020B	147	065-8020B	282	082-8020B	176	085-8020B	322
720 - 880	Plano-concave	-250	062-8025B	147	065-8025B	282	082-8025B	176	085-8025B	322
720 - 880	Plano-concave	-500	062-8050B	147	065-8050B	282	082-8050B	176	085-8050B	322
720 - 880	Plano-concave	-1000	062-8100B	147	065-8100B	282	082-8100B	176	085-8100B	322
720 - 880	Plano-concave	-2000	062-8200B	147	065-8200B	282	082-8200B	176	085-8200B	322
720 - 880	Plano-concave	-2500	062-8250B	147	065-8250B	282	082-8250B	176	085-8250B	322
720 - 880	Plano-concave	-3000	062-8300B	147	065-8300B	282	082-8300B	176	085-8300B	322
720 - 880	Plano-concave	-4000	062-8400B	147	065-8400B	282	082-8400B	176	085-8400B	322
720 - 880	Plano-concave	-5000	062-8500B	147	065-8500B	282	082-8500B	176	085-8500B	322
720 - 880	Plano-convex	+100	062-9010B	152	065-9010B	288	082-9010B	181	085-9010B	328
720 - 880	Plano-convex	+200	062-9020B	152	065-9020B	288	082-9020B	181	085-9020B	328
720 - 880	Plano-convex	+500	062-9050B	152	065-9050B	288	082-9050B	181	085-9050B	328
720 - 880	Plano-convex	+600	062-9060B	152	065-9060B	288	082-9060B	181	085-9060B	328
720 - 880	Plano-convex	+1000	062-9100B	152	065-9100B	288	082-9100B	181	085-9100B	328
720 - 880	Plano-convex	+1500	062-9150B	152	065-9150B	288	082-9150B	181	085-9150B	328
720 - 880	Plano-convex	+2000	062-9200B	152	065-9200B	288	082-9200B	181	085-9200B	328
720 - 880	Plano-convex	+4000	062-9400B	152	065-9400B	288	082-9400B	181	085-9400B	328

* Thickness of plano-plano rear mirrors of Ø50.8 is 8 mm.

Related Products

Uncoated Curved Windows

Find more at EksmaOptics.com

Kinematic Mirror Mount 840-0010

Find more at EksmaOptics.com



Kinematic Mirror Mount 840-0032, 840-0033

Find more at EksmaOptics.com



LASER BEAMSPLITTERS

Beamsplitter splits average polarized laser beam in two beams separated 90° from each other. The standard substrate thickness is 3 mm. If you need thinner substrate, please, choose from chapter Precision Thin Round Windows.

Please contact us for wedged beamsplitters or choose wedged substrates from Wedge Prisms

Coating

Technology	Electron beam multilayer dielectric
Adhesion and durability	Per MIL-C-675A. Insoluble in lab solvents
Clear aperture	Exceeds central 85% of diameter
Angle of incidence	45±3°
Back side antireflection coated	R<0.5%

Substrate

Material	UV grade Fused Silica
S1 surface flatness	λ/10 typical at 633 nm
S1 surface quality	20–10 scratch & dig (MIL-PRF-13830B)
S2 surface flatness	λ/10 typical at 633 nm
S2 surface quality	20–10 scratch & dig (MIL-PRF-13830B)
Diameter tolerance	+0.00 mm; -0.12 mm
Thickness tolerance	±0.25 mm
Parallelism	< 30 arcsec
Chamfer	0.3 mm at 45° typical

Designed for average polarization: $R = (R_s + R_p)/2$ and $T = (T_s + T_p)/2$.
Laser Damage Threshold: >100 mJ/cm², 50 fsec pulse, 50 Hz, 800 nm typical

Wavelength, nm	Reflection, %	Transmission, %	Substrate material	Ø12.7 × 3 mm		Ø25.4 × 3 mm		Ø50.8 × 8 mm	
				Catalogue number	Price, EUR	Catalogue number	Price, EUR	Catalogue number	Price, EUR
1030	20±3	80±3	UV FS	031-7420A	121	032-7420A	144	035-7420A	236
1030	30±3	70±3	UV FS	031-7430A	121	032-7430A	144	035-7430A	236
1030	50±3	50±3	UV FS	031-7450A	121	032-7450A	144	035-7450A	236
1030	70±3	30±3	UV FS	031-7470A	121	032-7470A	144	035-7470A	236
1030	80±3	20±3	UV FS	031-7480A	121	032-7480A	144	035-7480A	236
515	20±3	80±3	UV FS	031-7520A	118	032-7520A	141	035-7520A	230
515	30±3	70±3	UV FS	031-7530A	118	032-7530A	141	035-7530A	230
515	50±3	50±3	UV FS	031-7550A	118	032-7550A	141	035-7550A	230
515	70±3	30±3	UV FS	031-7570A	118	032-7570A	141	035-7570A	230
515	80±3	20±3	UV FS	031-7580A	118	032-7580A	141	035-7580A	230
343	20±3	80±3	UV FS	031-7620A	127	032-7620A	161	035-7620A	282
343	30±3	70±3	UV FS	031-7630A	127	032-7630A	161	035-7630A	282
343	50±3	50±3	UV FS	031-7650A	127	032-7650A	161	035-7650A	282
343	70±3	30±3	UV FS	031-7670A	127	032-7670A	161	035-7670A	282
343	80±3	20±3	UV FS	031-7680A	127	032-7680A	161	035-7680A	282
800	20±3	80±3	UV FS	041-7720A	121	042-7720A	144	045-7720A	236
800	30±3	70±3	UV FS	041-7730A	121	042-7730A	144	045-7730A	236
800	50±3	50±3	UV FS	041-7750A	121	042-7750A	144	045-7750A	236
800	70±3	30±3	UV FS	041-7770A	121	042-7770A	144	045-7770A	236
800	80±3	20±3	UV FS	041-7780A	121	042-7780A	144	045-7780A	236
400	20±3	80±3	UV FS	041-7820A	118	042-7820A	141	045-7820A	230
400	30±3	70±3	UV FS	041-7830A	118	042-7830A	141	045-7830A	230
400	50±3	50±3	UV FS	041-7850A	118	042-7850A	141	045-7850A	230
400	70±3	30±3	UV FS	041-7870A	118	042-7870A	141	045-7870A	230
400	80±3	20±3	UV FS	041-7880A	118	042-7880A	141	045-7880A	230
266	20±3	80±3	UV FS	041-7920A	132	042-7920FA	167	045-7920A	305
266	30±3	70±3	UV FS	041-7930A	132	042-7930FA	167	045-7930A	305
266	50±3	50±3	UV FS	041-7950A	132	042-7950FA	167	045-7950A	305
266	70±3	30±3	UV FS	041-7970A	132	042-7970FA	167	045-7970A	305
266	80±3	20±3	UV FS	041-7980A	132	042-7980FA	167	045-7980A	305

Designed for S- polarization. Laser Damage Threshold: >100 mJ/cm², 50 fsec pulse, 50 Hz, 800 nm typical

Wavelength, nm	Reflection, %	Transmission, %	Substrate material	Ø12.7 × 3 mm		Ø25.4 × 3 mm		Ø50.8 × 8 mm	
				Catalogue no.	Price, EUR	Catalogue no.	Price, EUR	Catalogue no.	Price, EUR
1030	20±3	80±3	UV FS	031-7420S	121	032-7420S	144	035-7420S	236
1030	30±3	70±3	UV FS	031-7430S	121	032-7430S	144	035-7430S	236
1030	50±3	50±3	UV FS	031-7450S	121	032-7450S	144	035-7450S	236
1030	70±3	30±3	UV FS	031-7470S	121	032-7470S	144	035-7470S	236
1030	80±3	20±3	UV FS	031-7480S	121	032-7480S	144	035-7480S	236
515	20±3	80±3	UV FS	031-7520S	118	032-7520S	141	035-7520S	230
515	30±3	70±3	UV FS	031-7530S	118	032-7530S	141	035-7530S	230
515	50±3	50±3	UV FS	031-7550S	118	032-7550S	141	035-7550S	230
515	70±3	30±3	UV FS	031-7570S	118	032-7570S	141	035-7570S	230
515	80±3	20±3	UV FS	031-7580S	118	032-7580S	141	035-7580S	230
343	20±3	80±3	UV FS	031-7620S	127	032-7620S	161	035-7620S	282
343	30±3	70±3	UV FS	031-7630S	127	032-7630S	161	035-7630S	282
343	50±3	50±3	UV FS	031-7650S	127	032-7650S	161	035-7650S	282
343	70±3	30±3	UV FS	031-7670S	127	032-7670S	161	035-7670S	282
343	80±3	20±3	UV FS	031-7680S	127	032-7680S	161	035-7680S	282
800	20±3	80±3	UV FS	041-7720S	121	042-7720S	144	045-7720S	236
800	30±3	70±3	UV FS	041-7730S	121	042-7730S	144	045-7730S	236
800	50±3	50±3	UV FS	041-7750S	121	042-7750S	144	045-7750S	236
800	70±3	30±3	UV FS	041-7770S	121	042-7770S	144	045-7770S	236
800	80±3	20±3	UV FS	041-7780S	121	042-7780S	144	045-7780S	236
400	20±3	80±3	UV FS	041-7820S	118	042-7820S	141	045-7820S	230
400	30±3	70±3	UV FS	041-7830S	118	042-7830S	141	045-7830S	230
400	50±3	50±3	UV FS	041-7850S	118	042-7850S	141	045-7850S	230
400	70±3	30±3	UV FS	041-7870S	118	042-7870S	141	045-7870S	230
400	80±3	20±3	UV FS	041-7880S	118	042-7880S	141	045-7880S	230
266	20±3	80±3	UV FS	041-7920S	132	042-7920FS	167	045-7920S	305
266	30±3	70±3	UV FS	041-7930S	132	042-7930FS	167	045-7930S	305
266	50±3	50±3	UV FS	041-7950S	132	042-7950FS	167	045-7950S	305
266	70±3	30±3	UV FS	041-7970S	132	042-7970FS	167	045-7970S	305
266	80±3	20±3	UV FS	041-7980S	132	042-7980FS	167	045-7980S	305

Designed for P- polarization. Laser Damage Threshold: >100 mJ/cm², 50 fsec pulse, 50 Hz, 800 nm typical

Wavelength, nm	Reflection, %	Transmission, %	Substrate material	Ø12.7 × 3 mm		Ø25.4 × 3 mm		Ø50.8 × 8 mm	
				Catalogue no.	Price, EUR	Catalogue no.	Price, EUR	Catalogue no.	Price, EUR
1030	20±3	80±3	UV FS	031-7420P	121	032-7420P	144	035-7420P	236
1030	30±3	70±3	UV FS	031-7430P	121	032-7430P	144	035-7430P	236
1030	50±3	50±3	UV FS	031-7450P	121	032-7450P	144	035-7450P	236
1030	70±3	30±3	UV FS	031-7470P	121	032-7470P	144	035-7470P	236
1030	80±3	20±3	UV FS	031-7480P	121	032-7480P	144	035-7480P	236
515	20±3	80±3	UV FS	031-7520P	118	032-7520P	141	035-7520P	230
515	30±3	70±3	UV FS	031-7530P	118	032-7530P	141	035-7530P	230
515	50±3	50±3	UV FS	031-7550P	118	032-7550P	141	035-7550P	230
515	70±3	30±3	UV FS	031-7570P	118	032-7570P	141	035-7570P	230
515	80±3	20±3	UV FS	031-7580P	118	032-7580P	141	035-7580P	230
343	20±3	80±3	UV FS	031-7620P	127	032-7620P	161	035-7620P	282
343	30±3	70±3	UV FS	031-7630P	127	032-7630P	161	035-7630P	282
343	50±3	50±3	UV FS	031-7650P	127	032-7650P	161	035-7650P	282
343	70±3	30±3	UV FS	031-7670P	127	032-7670P	161	035-7670P	282
343	80±3	20±3	UV FS	031-7680P	127	032-7680P	161	035-7680P	282
800	20±3	80±3	UV FS	041-7720P	121	042-7720P	144	045-7720P	236
800	30±3	70±3	UV FS	041-7730P	121	042-7730P	144	045-7730P	236
800	50±3	50±3	UV FS	041-7750P	121	042-7750P	144	045-7750P	236
800	70±3	30±3	UV FS	041-7770P	121	042-7770P	144	045-7770P	236
800	80±3	20±3	UV FS	041-7780P	121	042-7780P	144	045-7780P	236
400	20±3	80±3	UV FS	041-7820P	118	042-7820P	141	045-7820P	230
400	30±3	70±3	UV FS	041-7830P	118	042-7830P	141	045-7830P	230
400	50±3	50±3	UV FS	041-7850P	118	042-7850P	141	045-7850P	230
400	70±3	30±3	UV FS	041-7870P	118	042-7870P	141	045-7870P	230
400	80±3	20±3	UV FS	041-7880P	118	042-7880P	141	045-7880P	230
266	20±3	80±3	UV FS	041-7920P	132	042-7920FP	167	045-7920P	305
266	30±3	70±3	UV FS	041-7930P	132	042-7930FP	167	045-7930P	305
266	50±3	50±3	UV FS	041-7950P	132	042-7950FP	167	045-7950P	305
266	70±3	30±3	UV FS	041-7970P	132	042-7970FP	167	045-7970P	305
266	80±3	20±3	UV FS	041-7980P	132	042-7980FP	167	045-7980P	305

BROADBAND LASER BEAMSPLITTERS

Designed for S- polarization. Laser Damage Threshold: $>50 \text{ mJ/cm}^2$, 50 fsec pulse, 50 Hz, 800 nm typical

Wavelength, nm	Reflection, %	Transmission, %	Substrate material	Ø25.4 × 3 mm		Ø50.8 × 6 mm	
				Catalogue no.	Price, EUR	Catalogue no.	Price, EUR
720 – 880	8±1	92±1	UV FS	042-7708SB	127	045-7708SB	213
720 – 880	20±5	80±5	UV FS	042-7720SB	213	045-7720SB	391
720 – 880	30±5	70±5	UV FS	042-7730SB	213	045-7730SB	391
720 – 880	40±5	60±5	UV FS	042-7740SB	213	045-7740SB	391
720 – 880	50±5	50±5	UV FS	042-7750SB	213	045-7750SB	391
720 – 880	60±5	40±5	UV FS	042-7760SB	219	045-7760SB	414
720 – 880	70±5	30±5	UV FS	042-7770SB	224	045-7770SB	449
720 – 880	80±5	20±5	UV FS	042-7780SB	224	045-7780SB	449
720 – 880	90±3	10±3	UV FS	042-7790SB	247	045-7790SB	506
720 – 880	95±2	5±2	UV FS	042-7795SB	259	045-7795SB	541

Designed for P- polarization. Laser Damage Threshold: $>50 \text{ mJ/cm}^2$, 50 fsec pulse, 50 Hz, 800 nm typical

Wavelength, nm	Reflection, %	Transmission, %	Substrate material	Ø25.4 × 3 mm		Ø50.8 × 6 mm																																																																
				Catalogue no.	Price, EUR	Catalogue no.	Price, EUR																																																															
750 – 850	10±2	90±2	UV FS	042-7708PB	213	045-7708PB	391																																																															
750 – 850	20±5	80±5	UV FS	042-7720PB	213	045-7720PB	391																																																															
750 – 850	25±5	75±5	UV FS	042-7725PB	213	045-7725PB	391																																																															
750 – 850	30±5	70±5	UV FS	042-7730PB	213	045-7730PB	391																																																															
750 – 850	40±5	60±5	UV FS	042-7740PB	213	045-7740PB </tr <tr> <td>750 – 850</td> <td>50±5</td> <td>50±5</td> <td>UV FS</td> <td>042-7750PB</td> <td>213</td> <td>045-7750PB</td> <td>391</td> </tr> <tr> <td>750 – 850</td> <td>60±5</td> <td>40±5</td> <td>UV FS</td> <td>042-7760PB</td> <td>219</td> <td>045-7760PB</td> <td>414</td> </tr> <tr> <td>750 – 850</td> <td>70±5</td> <td>30±5</td> <td>UV FS</td> <td>042-7770PB</td> <td>224</td> <td>045-7770PB</td> <td>449</td> </tr> <tr> <td>750 – 850</td> <td>75±5</td> <td>25±5</td> <td>UV FS</td> <td>042-7775PB</td> <td>224</td> <td>045-7775PB</td> <td>449</td> </tr> <tr> <td>750 – 850</td> <td>80±5</td> <td>20±5</td> <td>UV FS</td> <td>042-7780PB</td> <td>224</td> <td>045-7780PB</td> <td>449</td> </tr> <tr> <td>750 – 850</td> <td>85±3</td> <td>15±3</td> <td>UV FS</td> <td>042-7785PB</td> <td>236</td> <td>045-7785PB</td> <td>483</td> </tr> <tr> <td>750 – 850</td> <td>90±3</td> <td>10±3</td> <td>UV FS</td> <td>042-7790PB</td> <td>247</td> <td>045-7790PB</td> <td>506</td> </tr> <tr> <td>750 – 850</td> <td>95±2</td> <td>5±2</td> <td>UV FS</td> <td>042-7795PB</td> <td>259</td> <td>045-7795PB</td> <td>541</td> </tr>	750 – 850	50±5	50±5	UV FS	042-7750PB	213	045-7750PB	391	750 – 850	60±5	40±5	UV FS	042-7760PB	219	045-7760PB	414	750 – 850	70±5	30±5	UV FS	042-7770PB	224	045-7770PB	449	750 – 850	75±5	25±5	UV FS	042-7775PB	224	045-7775PB	449	750 – 850	80±5	20±5	UV FS	042-7780PB	224	045-7780PB	449	750 – 850	85±3	15±3	UV FS	042-7785PB	236	045-7785PB	483	750 – 850	90±3	10±3	UV FS	042-7790PB	247	045-7790PB	506	750 – 850	95±2	5±2	UV FS	042-7795PB	259	045-7795PB	541
750 – 850	50±5	50±5	UV FS	042-7750PB	213	045-7750PB	391																																																															
750 – 850	60±5	40±5	UV FS	042-7760PB	219	045-7760PB	414																																																															
750 – 850	70±5	30±5	UV FS	042-7770PB	224	045-7770PB	449																																																															
750 – 850	75±5	25±5	UV FS	042-7775PB	224	045-7775PB	449																																																															
750 – 850	80±5	20±5	UV FS	042-7780PB	224	045-7780PB	449																																																															
750 – 850	85±3	15±3	UV FS	042-7785PB	236	045-7785PB	483																																																															
750 – 850	90±3	10±3	UV FS	042-7790PB	247	045-7790PB	506																																																															
750 – 850	95±2	5±2	UV FS	042-7795PB	259	045-7795PB	541																																																															

Related Products

Uncoated Elliptical Mirrors

Find more at EksmaOptics.com

Kinematic Mirror / Beamsplitter Mounts 840-0056

Find more at
EksmaOptics.com



Adapter for Beamsplitter at 45° 840-0116

Find more at
EksmaOptics.com



Flipping Mirror / Beamsplitter Mount 840-0155

Find more at
EksmaOptics.com

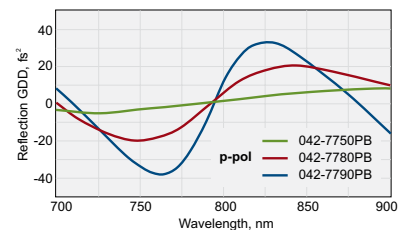
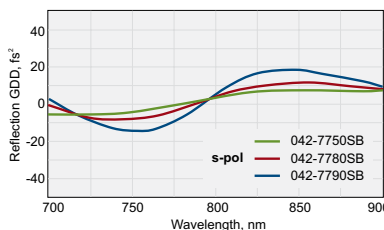
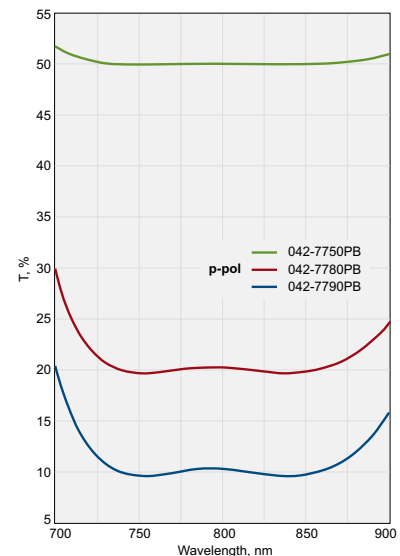
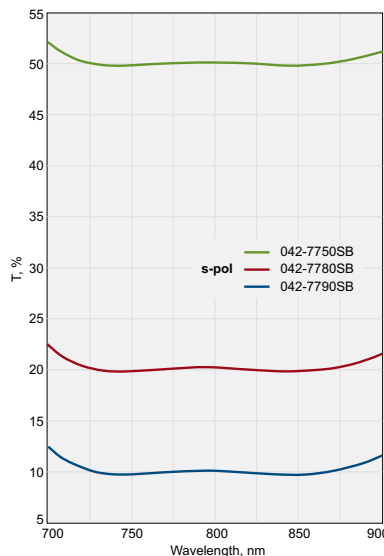

042-7750SB. $R_s=50\pm5\%$ @ 720–880 nm, AOI=45°
042-7780SB. $R_p=80\pm5\%$ @ 720–880 nm, AOI=45°
042-7790SB. $R_p=90\pm3\%$ @ 720–880 nm, AOI=45°

042-7750PB. $R_p=50\pm5\%$ @ 750–850 nm, AOI=45°
042-7780PB. $R_p=80\pm5\%$ @ 750–850 nm, AOI=45°
042-7790PB. $R_p=90\pm3\%$ @ 750–850 nm, AOI=45°

THIN LENSES

Features

- Very thin: edge thickness varies from 0.5-1.9 mm
- Centre thickness varies from 1-3 mm
- Plano-Convex or Plano-Concave type
- Uncoated,
 AR coated @ 333-353 nm, AR coated @ 380-420 nm,
 AR coated @ 500-530 nm, AR coated @ 515+1030 nm,
 AR coated @ 760-840 nm, AR coated @ 1000-1060 nm,
 AR coated @ 700-900 nm, AR coated @ 350-900 nm

Specifications

Material	UV FS
Surface quality	40-20 scratch & dig (MIL-PRF-13830B)
Clear aperture	85% of the diameter
Diameter tolerance	+0.00; -0.12 mm
Thickness tolerance	±0.2 mm
Surface irregularity	$\lambda/6$ @ 633 nm
Concentricity	3 arcmin
Paraxial focal length	±2% @ 800 nm

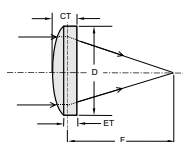

Plano-convex lens

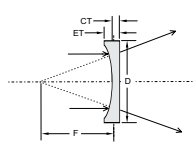

Plano-concave lens

THIN PLANO-CONCAVE LENSES, Ø12.7 mm

Uncoated lenses. Material – UVFS

Focal Length, mm @ 800 nm	Centre Thickness CT, mm	Edge Thickness ET, mm	Radius, mm	Catalogue number	Price, EUR
-20	1	3.5	-9.1	112-1104ET	60
-30	1	2.5	-13.6	112-1106ET	60
-40	1	2.1	-18.1	112-1108ET	60
-50	1	1.9	-22.7	112-1109ET	60
-60	1	1.7	-27.2	112-1110ET	60
-75	1	1.5	-34.0	112-1112ET	60
-80	1	1.5	-36.3	112-1113ET	60
-100	1	1.4	-45.3	112-1115ET	60
-125	1	1.3	-56.7	112-1117ET	60
-150	1	1.2	-68.0	112-1119ET	60

THIN PLANO-CONCAVE LENSES, Ø25.4 mm

Uncoated lenses. Material – UVFS

Focal Length, mm @ 800 nm	Centre Thickness CT, mm	Edge Thickness ET, mm	Radius, mm	Catalogue number	Price, EUR
-50	1.5	5.4	-22.7	112-1205ET	80
-75	1.5	4.0	-34.0	112-1209ET	80
-100	1.5	3.3	-45.4	112-1211ET	80
-125	1.5	3.0	-56.7	112-1215ET	80
-150	1.5	2.7	-68.0	112-1217ET	80
-200	1.5	2.4	-90.7	112-1219ET	80
-250	1.5	2.3	-113.3	112-1221ET	80
-300	1.5	2.1	-136.0	112-1223ET	80
-500	1.5	1.9	-226.7	112-1233ET	80

THIN PLANO-CONVEX LENSES, Ø12.7 mm

Uncoated lenses. Material – UVFS

Focal Length, mm @ 800 nm	Centre Thickness CT, mm	Edge Thickness ET, mm	Radius, mm	Catalogue number	Price, EUR
30	2.5	1.0	13.6	110-1106ET	60
40	1.8	0.7	18.1	110-1108ET	60
50	1.9	1.0	22.7	110-1109ET	60
75	1.8	1.2	34.0	110-1111ET	60
100	1.5	0.9	45.3	110-1115ET	60
125	1.4	1.0	56.7	110-1117ET	60
150	1.5	1.2	68.0	110-1119ET	60
175	1.2	1.0	79.3	110-1121ET	60
200	1.2	1.0	90.7	110-1123ET	60
250	1.1	1.0	113.3	110-1126ET	60
300	1.5	1.4	136.0	110-1129ET	60
400	1.1	1.0	181.3	110-1133ET	60
450	1.1	1.0	204.0	110-1135ET	60
500	1.1	1.0	226.7	110-1137ET	60

THIN PLANO-CONVEX LENSES, Ø25.4 mm

Uncoated lenses. Material – UVFS

Focal Length, mm @ 800 nm	Centre Thickness CT, mm	Edge Thickness ET, mm	Radius, mm	Catalogue number	Price, EUR
50	4.9	1.0	22.7	110-1205ET	80
75	3	0.5	34.0	110-1209ET	80
80	3	0.7	36.3	110-1210ET	80
100	2.5	0.7	45.3	110-1211ET	80
125	2	0.6	56.7	110-1216ET	80
150	2	0.8	68.0	110-1217ET	80
200	2	1.1	90.7	110-1219ET	80
250	2	1.3	113.3	110-1221ET	80
300	2	1.4	136.0	110-1223ET	80
350	2	1.5	158.7	110-1225ET	80
400	2	1.6	181.3	110-1227ET	80
450	2	1.6	204.0	110-1231ET	80
500	2	1.6	226.7	110-1233ET	80
1000	1.5	1.3	453.3	110-1245ET	80
1500	1.4	1.3	680.0	110-1255ET	80
2000	1.4	1.3	906.6	110-1265ET	80
3000	1.4	1.3	1360.1	110-1267ET	80

THIN PLANO-CONVEX LENSES, Ø50.8 mm

Uncoated lenses. Material – UVFS

Focal Length, mm @ 800 nm	Centre Thickness CT, mm	Edge Thickness ET, mm	Radius, mm	Catalogue number	Price, EUR
75	14	2.5	34.0	110-1505ET	180
100	10.3	2.5	45.3	110-1509ET	180
150	7.4	2.5	68.0	110-1511ET	180
200	6.1	2.5	90.7	110-1515ET	180
300	4.9	2.5	136.0	110-1519ET	180
400	4.3	2.5	181.3	110-1523ET	180
500	3.9	2.5	226.7	110-1527ET	180
1000	3.2	2.5	453.3	110-1545ET	180
1500	3	2.5	680.0	110-1550ET	180
2000	2.9	2.5	906.6	110-1555ET	180
3000	2.7	2.5	1360.0	110-1566ET	180
4000	2.7	2.5	1813.3	110-1568ET	180
5000	2.6	2.5	2266.6	110-1567ET	180
6000	2.6	2.5	2719.9	110-1570ET	180

AVAILABLE STANDARD COATINGS FOR THIN LENSES

Specifications

Technology	Electron beam multilayer dielectric
Adhesion and Durability	Per MIL-C-675A. Insoluble in lab solvents
Clear Aperture	Exceeds central 85% of diameter
Angle of Incidence	0°

Available Coatings

Wavelength	Reflection per surface	Laser Damage Threshold *	Coating suffix	Price per unit to be added, EUR/pc.
760 – 840 nm	R<0.5%	100 mJ/cm ²	AR800	35
700 – 900 nm	R<0.5%	50 mJ/cm ²	ARB800	60
350 – 900 nm	R<1.5%	50 mJ/cm ²	ARB625	72
1000 – 1060 nm	R<0.3%	100 mJ/cm ²	AR1030	35
500 – 530 nm	R<0.4%	100 mJ/cm ²	AR515	35
380 – 420 nm	R<0.5%	100 mJ/cm ²	AR400	35
333 – 353 nm	R<0.5%	100 mJ/cm ²	AR343	35
515 + 1030 nm	R<0.5%	100 mJ/cm ²	ARD1030	42

* Measured at design wavelength, 50 fs, 50 Hz.

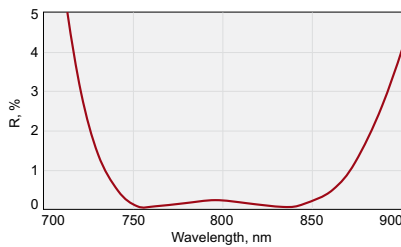

Reflectivity @ 760-840 nm

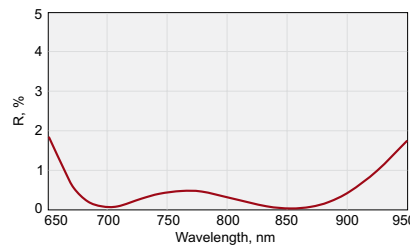

Reflectivity @ 700-900 nm

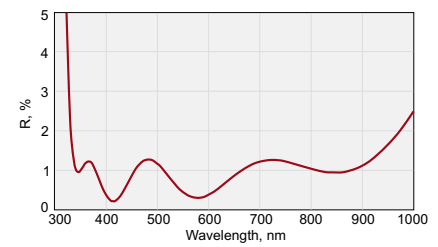

Reflectivity @ 350-900 nm

AVAILABLE IBS COATINGS FOR THIN LENSES

Specifications

Technology	Ion Beam Sputtering (IBS)
Adhesion and Durability	Per MIL-C-675A. Insoluble in lab solvents
Clear Aperture	Exceeds central 85% of diameter
Angle of Incidence	0°
Coated Surface Flatness	$\lambda/10$ at 633 nm over clear aperture

Available Coatings

Wavelength	Reflection per surface	Laser Damage Threshold *	Coating suffix	Price per unit to be added, EUR/pc.
760 – 840 nm	R<0.1%	100 mJ/cm ²	AR800HT	105
700 – 900 nm	R<0.1%	100 mJ/cm ²	ARB800HT	115
380 – 420 nm	R<0.2%	50 mJ/cm ²	AR400HT	105
400 + 800 nm	R<0.2%	50 mJ/cm ²	ARD800HT	115
1000 – 1060 nm	R<0.1%	100 mJ/cm ²	AR1030HT	105
500 – 530 nm	R<0.1%	50 mJ/cm ²	AR515HT	105
333 – 353 nm	R<0.2%	25 mJ/cm ²	AR343HT	135
515 + 1030 nm	R<0.1%	50 mJ/cm ²	ARD1030HT	115

* Measured at design wavelength, 50 fs, 50 Hz.

Ordering of Coated Thin Lenses

Please choose the coating and add its suffix to the lens code.

Example:

UVFS Thin Plano-Convex Lens, focal length 75 mm, coated AR / AR @ 760-840 nm
Code: **110-1209ET + AR800**, Price: 80 + 35 EUR = 115 EUR/pc.



AR COATED LENS KITS

LARGE UV FS SPHERICAL LENS KIT (40 pcs.)



Large Spherical Lens Kit

Lens kits contain different types of spherical (plano-convex, biconvex, plano-concave, biconcave) or cylindrical (plano-convex, plano-concave) lenses with various focal lengths. Kits are packed into foam lined plastic boxes for safe handling and storage. Kits are available with laser line and broadband multilayer anti-reflection coatings.

Spherical lens kits consist of 40 (large kit) or 15 (small kit) $\varnothing 25.4$ mm lenses made of UVFS.

Cylindrical lens kits consist of 12 rectangular lenses (25.4×50.8 mm) made of UVFS.

Coating	Catalogue number	Price, EUR
BBAR @ 210 – 400 nm, R<2%	140-1240-AR210-400	3839
BBAR @ 350 – 900 nm, R<1.5%	140-1240-AR350-900	3619
BBAR @ 760 – 840 nm, R<0.4%	140-1240-AR760-840	3344
BBAR @ 700 – 900 nm, R<0.8%	140-1240-AR700-900	3531
BBAR @ 650 – 1100 nm, R<1%	140-1240-AR650-1100	3641
AR @ 266 nm, R<0.4%	140-1240-AR266	3443
AR @ 1030 nm, R<0.25%	140-1240-AR1030	3223
AR @ 515 nm, R<0.25%	140-1240-AR515	3223
AR @ 343 nm, R<0.3%	140-1240-AR343	3333
AR @ 258 nm, R<0.4%	140-1240-AR258	3443

Large UV FS Spherical Lens Kit

Type	Dia, mm	F, mm	Catalogue number
pl/cx	25.4	30	110-1203E
pl/cx	25.4	50	110-1205E
pl/cx	25.4	75	110-1209E
pl/cx	25.4	80	110-1210E
pl/cx	25.4	100	110-1211E
pl/cx	25.4	125	110-1216E
pl/cx	25.4	150	110-1217E
pl/cx	25.4	200	110-1219E
pl/cx	25.4	250	110-1221E
pl/cx	25.4	300	110-1223E
pl/cx	25.4	350	110-1225E
pl/cx	25.4	400	110-1227E
pl/cx	25.4	500	110-1233E
pl/cx	25.4	600	110-1235E
pl/cx	25.4	750	110-1239E
pl/cx	25.4	1000	110-1245E
bi/cx	25.4	25	111-1204E
bi/cx	25.4	40	111-1207E
bi/cx	25.4	50	111-1210E
bi/cx	25.4	75	111-1214E

Type	Dia, mm	F, mm	Catalogue number
bi/cx	25.4	100	111-1218E
bi/cx	25.4	150	111-1222E
bi/cx	25.4	200	111-1226E
bi/cx	25.4	250	111-1230E
bi/cx	25.4	300	111-1234E
bi/cx	25.4	400	111-1238E
bi/cx	25.4	500	111-1240E
bi/cx	25.4	1000	111-1260E
pl/cv	25.4	-50	112-1205E
pl/cv	25.4	-75	112-1209E
pl/cv	25.4	-100	112-1211E
pl/cv	25.4	-150	112-1217E
pl/cv	25.4	-200	112-1219E
pl/cv	25.4	-300	112-1223E
pl/cv	25.4	-25	114-1204E
bi/cv	25.4	-50	114-1208E
bi/cv	25.4	-75	114-1212E
bi/cv	25.4	-100	114-1216E
bi/cv	25.4	-150	114-1220E
bi/cv	25.4	-200	114-1224E

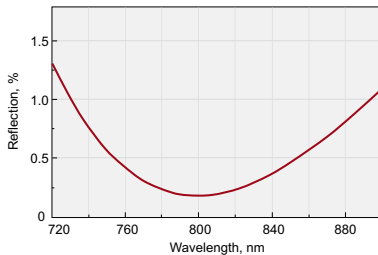

R<0.5% @ 760-840 nm, AOI= 0°

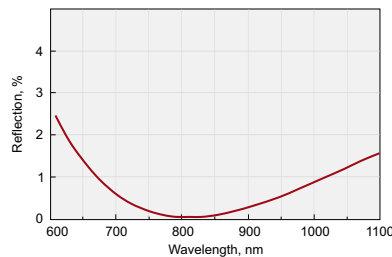

R<0.8% @ 700-900 nm, AOI= 0°

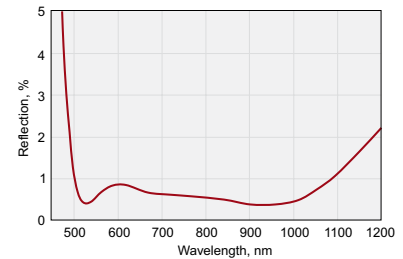

R<1.5% @ 500-1100 nm, AOI=0°

SMALL UV FS SPHERICAL LENS KIT (15 pcs.)

Coating	Code	Price, EUR
BBAR @ 210 – 400 nm, R<2%	140-1215-AR210-400	2013
BBAR @ 350 – 900 nm, R<1.5%	140-1215-AR350-900	1826
BBAR @ 760 – 840 nm, R<0.4%	140-1215-AR760-840	1683
BBAR @ 700 – 900 nm, R<0.8%	140-1215-AR700-900	1771
BBAR @ 650 – 1100 nm, R<1%	140-1215-AR650-1100	1837
AR @ 266 nm, R<0.4%	140-1215-AR266	1518
AR @ 1030 nm, R<0.25%	140-1215-AR1030	1452
AR @ 515 nm, R<0.25%	140-1215-AR515	1452
AR @ 343 nm, R<0.3%	140-1215-AR343	1485
AR @ 258 nm, R<0.4%	140-1215-AR258	1485

Small UV FS Spherical Lens Kit

Type	Dia, mm	F, mm	Catalogue number
pl/cx	25.4	30	110-1203E
pl/cx	25.4	50	110-1205E
pl/cx	25.4	75	110-1209E
pl/cx	25.4	100	110-1211E
pl/cx	25.4	125	110-1216E
pl/cx	25.4	150	110-1217E
pl/cx	25.4	200	110-1219E
pl/cx	25.4	300	110-1223E

Type	Dia, mm	F, mm	Catalogue number
pl/cx	25.4	500	110-1233E
pl/cx	25.4	1000	110-1245E
pl/cv	25.4	-50	112-1205E
pl/cv	25.4	-75	112-1209E
pl/cv	25.4	-100	112-1211E
pl/cv	25.4	-125	112-1215E
pl/cv	25.4	-150	112-1217E

UV FS CYLINDRICAL LENS KIT (12 pcs.)

Coating	Catalogue number	Price, EUR
AR @ 210 – 400nm, R<2%	140-1212-ARB300	2992
AR @ 350 – 900nm, R<1.5%	140-1212-ARB625	2893
AR @ 515 + 1030nm, R<0.5%	140-1212-ARD1030	2607
AR @ 700 – 900nm, R<0.5%	140-1212-ARB800	2750
AR @ 650 – 1100nm, R<0.7%	140-1212-ARB825	2805
AR @ 1000 – 1060nm, R<0.3%	140-1212-AR1030	2530
AR @ 515 + 1030nm, R<0.1%	140-1212-ARD1030HT	3630
AR @ 700 – 900nm, R<0.1%	140-1212-ARB800HT	3740
AR @ 900 – 1100nm, R<0.1%	140-1212-ARB1000HT	3740

UV FS Cylindrical Lens Kit

Type	Size, mm	F, mm	Catalogue number
pl/cx	25.4 × 50.8	50	120-1205E
pl/cx	25.4 × 50.8	75	120-1210E
pl/cx	25.4 × 50.8	100	120-1215E
pl/cx	25.4 × 50.8	150	120-1220E
pl/cx	25.4 × 50.8	200	120-1225E
pl/cx	25.4 × 50.8	300	120-1230E

Type	Size, mm	F, mm	Catalogue number
pl/cx	25.4 × 50.8	500	120-1235E
pl/cx	25.4 × 50.8	1000	120-1240E
pl/cv	25.4 × 50.8	-50	122-1205E
pl/cv	25.4 × 50.8	-75	122-1210E
pl/cv	25.4 × 50.8	-100	122-1215E
pl/cv	25.4 × 50.8	-150	122-1220E

THIN FILM POLARIZERS (56° Angle of Incidence)

Thin film polarizers separate s- and p-polarization components. Due to their high laser damage threshold, thin film polarizers can be used as an alternative to Glan-Taylor laser polarizing prisms or cube polarizing beamsplitters.

Femtoline thin film laser polarizers are designed for use in high energy lasers. They can be used for Yb:KYW/KGW or Ti:Sapphire laser fundamental wavelengths or their harmonics, as well as intracavity Q-switch hold-off polarizers. The most efficient way to use these polarizers is at Brewster's angle – $56 \pm 2^\circ$.

Specifications

Technology	Ion Beam Sputtering
Material	BK7, UV FS
Surface quality	20–10 scratch & dig (ML-PRF-13830B)
Transmitted wavefront distortion	$\lambda/10$ @ 633 nm
Angle of incidence (AOI)	56°
Angle of incidence tolerance	$\pm 2^\circ$
Laser damage threshold	$>100 \text{ mJ/cm}^2$, 50 fsec pulse, 50 Hz, 800 nm typical

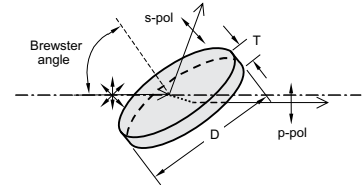

THIN FILM POLARIZERS WITH HIGH EXTINCTION RATIO

Round Polarizers. Material – UV FS. $T_p > 98\%$, $T_s < 0.1\%$.
Extinction ratio for transmitted light $T_p/T_s: >1000:1$

Wavelength, nm	Diameter D, mm	Thickness T, mm	Catalogue number	Price, EUR
343	25.4	3	420-1242HE	251
515	25.4	3	420-1244HE	213
800	25.4	3	420-1256HE	213
780 – 820	25.4	3	420-1266HE	316
1030	25.4	3	420-1248HE	248

Rectangular Polarizers. Material – UV FS. $T_p > 98\%$, $T_s < 0.1\%$.
Extinction ratio for transmitted light $T_p/T_s: >1000:1$

Wavelength, nm	Rectangular dimensions		Thickness T, mm	Catalogue number	Price, EUR
	Length, mm	Width, mm			
1030	20	15	6	420-1478HE	190
1030	30	20	6	420-1578HE	253

ULTRA HIGH TRANSMISSION THIN FILM POLARIZERS

Round Polarizers. Material – UV FS. $T_s < 0.2\%$, $R_p < 0.2\%$.
Extinction ratio for transmitted light $T_p/T_s > 500:1$

Wavelength, nm	Diameter D, mm	Thickness T, mm	Catalogue number	Price, EUR
800	25.4	3.0	420-1256UHT	299
1030	25.4	3.0	420-1248UHT	350

HIGH TRANSMISSION THIN FILM POLARIZERS

Round Polarizers. Material – UV FS. $R_s / T_p > 99.5 / 99.0\%$.
Extinction ratio for transmitted light $T_p/T_s > 200:1$

Wavelength, nm	Diameter D, mm	Thickness T, mm	Catalogue number	Price, EUR
343	25.4	3.0	420-1242HT	273
515	25.4	3.0	420-1244HT	230
800	25.4	3.0	420-1256HT	230
1030	25.4	3.0	420-1248HT	269

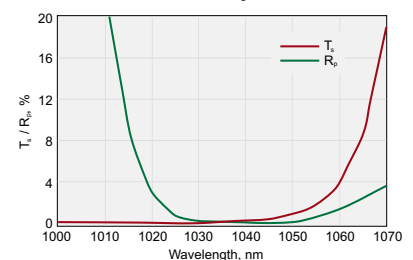
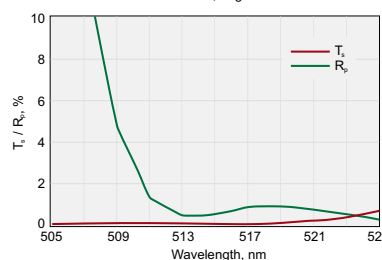
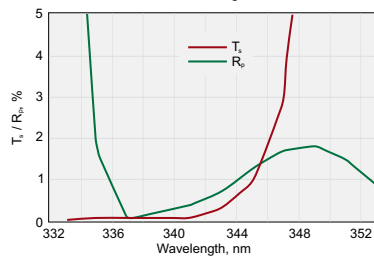
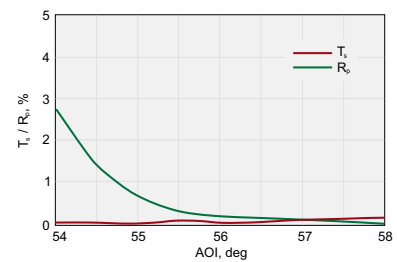
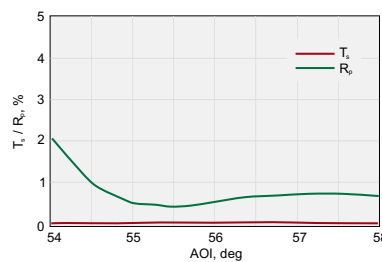
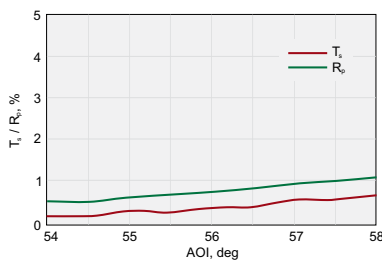

420-1242HT.
High Transmission @ 343 nm,
 $R_s/T_p > 99.5/99.0\%$, $AOI=56^\circ$

420-1244HT.
High Transmission @ 515 nm,
 $R_s/T_p > 99.5/99.0\%$, $AOI=56^\circ$

420-1248HT.
High Transmission @ 1030 nm,
 $R_s/T_p > 99.5/99.0\%$, $AOI=56^\circ$

STANDARD THIN FILM POLARIZERS

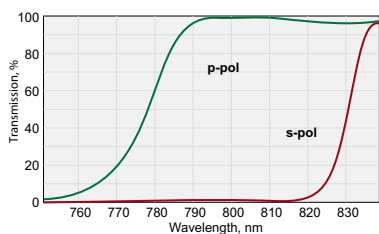

420-1126E.

Transmission @ 800 nm,
Rs/Tp > 99.5/95.0 %, AOI=56°

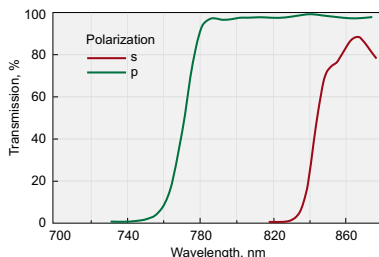

420-1136E.

Transmission @ 780-820 nm,
Rs/Tp > 99.5/95.0 %, AOI=56°

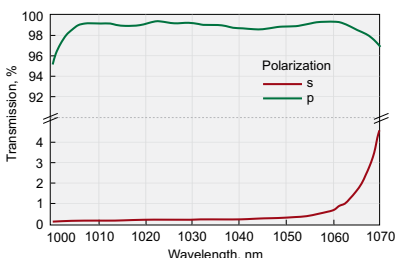

420-1268E.

Transmission @ 1010-1050 nm,
Rs/Tp > 99.5/95.0 %, AOI=56°

Please contact us if you need thin film laser polarizers of other wavelengths or other types of substrates.

Round Polarizers. Material – UV FS. Rs / Tp > 99.5 / 95.0%.
Extinction ratio for transmitted light Tp/Ts >200:1

Wavelength, nm	Diameter D, mm	Thickness T, mm	Catalogue number	Price, EUR
266	12.7	3.2	420-1110E	207
343	12.7	3.0	420-1112E	189
400	12.7	3.0	420-1123E	151
515	12.7	3.0	420-1114E	151
800	12.7	3.0	420-1126E	151
780-820	12.7	3.0	420-1136E	225
1030	12.7	3.0	420-1118E	167
1010-1050	12.7	3.0	420-1138E	225
266	25.4	3.0	420-1240E	230
343	25.4	3.0	420-1242E	209
400	25.4	3.0	420-1253E	177
515	25.4	3.0	420-1244E	177
800	25.4	3.0	420-1256E	177
780-820	25.4	3.0	420-1266E	266
1030	25.4	3.0	420-1248E	207
1010-1050	25.4	3.0	420-1268E	266
266	50.8	6.0	420-1510E	412
343	50.8	6.0	420-1512E	374
400	50.8	6.0	420-1503E	339
515	50.8	6.0	420-1514E	339
800	50.8	6.0	420-1506E	351
780-820	50.8	6.0	420-1526E	465
1030	50.8	6.0	420-1518E	362
1010-1050	50.8	6.0	420-1528E	465

Rectangular Polarizers. Material – UV FS. Rs / Tp > 99.5 / 95.0%.
Extinction ratio for transmitted light Tp/Ts >2 00:1

Wavelength, nm	Rectangular dimensions		Thickness T, mm	Catalogue number	Price, EUR
	Length, mm	Width, mm			
266	28.6	14.3	3.0	420-1270	306
343	28.6	14.3	3.0	420-1272	293
400	28.6	14.3	3.0	420-1283	247
515	28.6	14.3	3.0	420-1274	247
800	28.6	14.3	3.0	420-1286	247
780-820	28.6	14.3	3.0	420-1296	362
1030	28.6	14.3	3.0	420-1278	259
1010-1050	28.6	14.3	3.0	420-1298	362

Related Products

Glan Laser Polarizing, Wollaston Prisms

Find more at EksmaOptics.com

Adapters for Polarizer at 56° 840-0117, 840-0118

Find more at EksmaOptics.com



Variable Attenuators for Linearly Polarized Laser Beam 990-0070

See page 34



THIN FILM POLARIZERS (70° Angle of Incidence)

Broadband thin film polarizers separate the s- and p-polarization components in broad region at 70° angle of incidence (AOI). These polarizers are designed to be used in high energy laser systems, typically as extracavity attenuators for femtosecond lasers.

Polarizers are made from UV fused silica and feature a high laser damage threshold – up to 50 mJ/cm², 50 fsec pulse, 50 Hz, 800 nm typical.

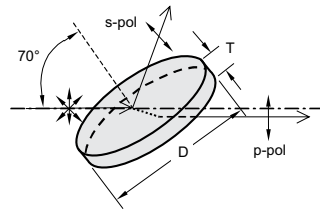

Specifications

Technology	Ion Beam Sputtering
Substrate material	UV FS
Surface quality	20–10 scratch & dig (MIL-PRF-13830B)
Transmitted wavefront distortion	$\lambda/10$ @ 633 nm
Clear aperture	>90% of diameter
Angle of incidence (AOI)	70°
Angle of incidence tolerance	$\pm 2^\circ$
Parallelism	<30 arcsec

Rectangular Polarizers. Material – UV FS. Extinction ratio for transmitted light $T_p/T_s > 200:1$

Operating wavelength region, nm	Polarization efficiency, R_s/T_p , %	Rectangular dimensions		Thickness T, mm	Catalogue number	Price, EUR
		Length, mm	Width, mm			
980 - 1080	> 99.5 / 95.0	60.0	20.0	4.0	420-1698BBi70	500
980 - 1080	> 99.5 / 95.0	60.0	20.0	12.0	420-1698T12BBi70	550
750 - 850	> 99.5 / 95.0	60.0	20.0	4.0	420-1696BBi70	500
750 - 850	> 99.5 / 95.0	60.0	20.0	12.0	420-1696T12BBi70	550
500 - 530	> 99.5 / 95.0	60.0	20.0	4.0	420-1615BBi70	500
500 - 530	> 99.5 / 95.0	60.0	20.0	12.0	420-1615T12BBi70	550
333 - 353	> 99.5 / 95.0	60.0	20.0	4.0	420-1643BBi70	525
333 - 353	> 99.5 / 95.0	60.0	20.0	12.0	420-1643T12BBi70	575
255 - 260	> 99.0 / 92.0	60.0	20.0	4.0	420-1657BBi70	525
255 - 260	> 99.0 / 92.0	60.0	20.0	12.0	420-1657T12BBi70	575

THIN FILM POLARIZERS (45° Angle of Incidence)

These thin film polarizers separate or combine the s- and p-polarization components at 45° angle of incidence. They are designed for use in high energy lasers. Polarizers are made from UV FS and feature high laser damage threshold reaching 10 J/cm² at 1064 nm.

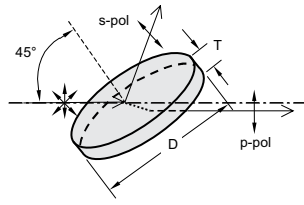

Specifications

Technology	Ion Beam Sputtering
Substrate material	UV FS
Surface quality	20–10 scratch & dig (MIL-PRF-13830B)
Transmitted wavefront distortion	$\lambda/10$ @ 633 nm
Clear aperture	>85% of diameter
Angle of incidence (AOI)	45°
Angle of incidence tolerance	$\pm 1^\circ$
Parallelism	<30 arcsec

TF POLARIZERS WITH HIGH EXTINCTION RATIO

Round Polarizers. Material – UV FS. $T_p > 98\%$, $T_s < 0.1\%$. Extinction ratio for transmitted light $T_p/T_s > 1000:1$

Wavelength, nm	Diameter D, mm	Thickness T, mm	Catalogue number	Price, EUR
343	25.4	3	420-1242i45HE	377
515	25.4	3	420-1244i45HE	339
1030	25.4	3	420-1248i45HE	362
343	50.8	6	420-1512i45HE	736
515	50.8	6	420-1514i45HE	638
1030	50.8	6	420-1518i45HE	713

STANDARD THIN FILM POLARIZERS

Round Polarizers. Material – UV FS. $R_s / T_p > 99.5 / 95.0\%$. Extinction ratio for transmitted light $T_p/T_s > 200:1$

Wavelength, nm	Diameter D, mm	Thickness T, mm	Catalogue number	Price, EUR
343	25.4	3	420-1242i45	274
515	25.4	3	420-1244i45	230
1030	25.4	3	420-1248i45	259
343	50.8	6	420-1512i45	523
515	50.8	6	420-1514i45	454
1030	50.8	6	420-1518i45	506

QUARTZ RETARDATION WAVEPLATES

Quartz Retardation Plates are made of material enabling linear birefringence. These plates are made of high quality optical grade crystalline quartz, featuring high damage threshold. Retardation plates rotate polarization's direction

($\lambda/2$) or convert linear into circular polarization or vice versa ($\lambda/4$). Quartz retardation plates are supplied mounted and AR coated.

ZERO ORDER OPTICALLY CONTACTED WAVEPLATES

Features

- Easily aligned
- Temperature insensitive
- Moderately insensitive to wavelength

Zero order plates are comprised of two different plates cut parallel to their optical axis. This construction makes plates less dependent on temperature. The plates are polished to different thicknesses enabling one to achieve required retardation difference. These component plates have orthogonal optic axis directions, so that the roles of the ordinary and extraordinary rays are interchanged in passing from one plate to another. The thickness of the plate determines the phase shift between the ordinary and extraordinary beams for any specific wavelength.



Specifications

Material	Single crystal quartz
Optical axis	normal to facet on circumference of retarder
Surface quality	20-10 scratch & dig (MIL-PRF-13830B)
Wavefront distortion	$\lambda/10$ @ 633 nm
Parallelism	< 10 arcsec
AR coating	R < 0.5%
Laser damage threshold	> 10 mJ/cm ² , 50 fsec pulse, 800 nm typical

Ø12.7 mm waveplates. Clear aperture Ø11 mm, unmounted

Center wavelength, nm	AR coating range, nm	Retardation $\lambda/2$		Retardation $\lambda/4$	
		Catalogue number	Price, EUR	Catalogue number	Price, EUR
1030	1000-1060	460-4208D12	165	460-4408D12	165
800	760-840	460-4215D12	165	460-4415D12	165
780	740-820	460-4220D12	165	460-4420D12	165
515	500-530	460-4232D12	165	460-4432D12	165
400	380-420	460-4235D12	165	460-4435D12	165
343	333-353	460-4241D12	175	460-4441D12	175
266	257-275	460-4245D12	185	460-4445D12	185
257	250-265	460-4246D12	185	460-4446D12	185

Related Products

Achromatic Air-Spaced Waveplates

Find more at EksmaOptics.com

Polarizer Holder 840-0180

Find more at EksmaOptics.com



High Precision Rotation Polarizer, Waveplate Mount 840-0186

Find more at EksmaOptics.com



Ø20 mm waveplates. Clear aperture Ø17 mm, mounted into Ø25.4 mm ring holder

Center wavelength, nm	AR coating range, nm	Retardation $\lambda/2$		Retardation $\lambda/4$	
		Catalogue number	Price, EUR	Catalogue number	Price, EUR
1030	1000-1060	460-4208	245	460-4408	245
800	760-840	460-4215	245	460-4415	245
780	740-820	460-4220	245	460-4420	245
515	500-530	460-4232	245	460-4432	245
400	380-420	460-4235	245	460-4435	245
343	333-353	460-4241	270	460-4441	270
266	257-275	460-4245	280	460-4445	280
257	250-265	460-4246	280	460-4446	280

ZERO ORDER AIR-SPACED WAVEPLATES

Features

- For high power laser applications



Specifications

Material	Single crystal quartz
Optical axis	normal to facet on circumference of retarder
Clear aperture	Ø17 mm
Ring mount outer diameter	25.4 +0.0 / -0.12 mm
Wavefront distortion	$\lambda/10$ @ 633 nm
Surface quality	20 – 10 scratch & dig (MIL-PRF-13830B)
Parallelism	< 10 arcsec
AR coating	R < 0.5%
Laser damage threshold	100 mJ/cm ² , 50 fsec pulse, 800 nm typical

Housing Accessories

Polarizer Holder 840-0180

Find more at EksmaOptics.com



Center wavelength, nm	AR coating range, nm	Retardation $\lambda/2$		Retardation $\lambda/4$	
		Catalogue number	Price, EUR	Catalogue number	Price, EUR
1030	1000-1060	464-4208	310	464-4408	310
800	760-840	464-4215	310	464-4415	310
780	740-820	464-4220	310	464-4420	310
515	500-530	464-4232	310	464-4432	310
400	380-420	464-4235	310	464-4435	310
343	333-353	464-4241	335	464-4441	335
266	257-275	464-4245	345	464-4445	345
257	250-265	464-4246	345	464-4446	345

ZERO ORDER DUAL WAVELENGTH WAVEPLATES

When optical axis is turned by 45 degrees to input polarization, the waveplate rotates polarization of Ti:Sapphire laser fundamental (800 nm) by 90 degrees and the polarization of Ti:Sapphire second harmonic (400 nm) remains the same.

Specifications

Material	Single crystal quartz
Optical axis	normal to facet on circumference of retarder
Clear aperture	Ø17 mm
Ring mount outer diameter	25.4 +0.0/-0.12 mm
Surface quality	20 – 10 scratch & dig (MIL-PRF-13830B)
Wavefront distortion	$\lambda/10$ @ 633 nm
Parallelism	<10 arcsec
AR coating	R<0.5%

Description	AR coated	Laser Damage Threshold	Application	Catalogue number	Price, EUR
optically contacted $\lambda/2@800$ nm + $\lambda@400$ nm	800+400 nm	>10 mJ/cm ² , 50 fsec pulse, 800 nm typical	Ti:Sapphire	465-4211	345
air-spaced $\lambda/2@800$ nm + $\lambda@400$ nm	800+400 nm	100 mJ/cm ² , 50 fsec pulse, 800 nm typical	Ti:Sapphire	466-4211	410
optically contacted $\lambda/2@1030$ nm + $\lambda@515$ nm	1030+515 nm	>10 mJ/cm ² , 50 fsec pulse, 1030 nm typical	Yb:KGW/KYW	465-4212	345
air-spaced $\lambda/2@1030$ nm + $\lambda@515$ nm	1030+515 nm	100 mJ/cm ² , 50 fsec pulse, 1030 nm typical	Yb:KGW/KYW	466-4212	410

Housing Accessories

Polarizer Holder 840-0180

Find more at EksmaOptics.com

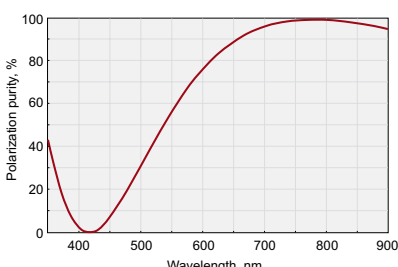

Polarization purity of zero order dual waveplate. $\lambda/2@800$ nm + $\lambda/400$ nm

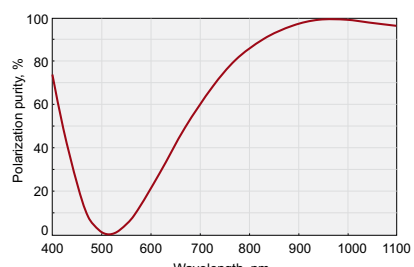

Polarization purity of zero order dual waveplate. $\lambda/2@1030$ nm + $\lambda/515$ nm

LOW ORDER WAVEPLATES

Features

- Thinner than multiple order

Low order plates are less temperature sensitive and temperature dependent than multiple order plates. These plates are suitable for high and low power applications.

Specifications

Material	Single crystal quartz
Optical axis	normal to facet on circumference of retarder
Surface quality	20-10 scratch & dig (MIL-PRF-13830B)
Wavefront distortion	$\lambda/10$ @ 633 nm
Parallelism	< 10 arcsec
AR coating	R < 0.5%
Laser damage threshold	100 mJ/cm ² , 50 fsec pulse, 800 nm typical

Ø12.7 mm waveplates. Clear aperture Ø11 mm, unmounted

Wavelength, nm	Retardation $\lambda/2$		Retardation $\lambda/4$	
	Catalogue number	Price, EUR	Catalogue number	Price, EUR
1030	461-4208D12	105	461-4408D12	105
800	461-4215D12	105	461-4415D12	105
780	461-4220D12	105	461-4420D12	105
515	461-4232D12	105	461-4432D12	105

Related Products

Low Order Plates of other wavelengths

Find more at EksmaOptics.com

High Precision Rotation Polarizer, Waveplate Mount 840-0186

Find more at EksmaOptics.com



Ø20 mm waveplates. Clear aperture Ø17 mm, mounted into Ø25.4 mm ring holder

Wavelength, nm	Retardation $\lambda/2$		Retardation $\lambda/4$	
	Catalogue number	Price, EUR	Catalogue number	Price, EUR
1030	461-4208	160	461-4408	160
800	461-4215	160	461-4415	160
780	461-4220	160	461-4420	160
515	461-4232	160	461-4432	160
400	461-4235	160	461-4435	160
343	461-4241	192	461-4441	192

MULTIPLE ORDER DUAL WAVELENGTH WAVEPLATES

Specifications

Material	Single crystal quartz
Optical axis	normal to facet on circumference of retarder
Wavefront distortion	$\lambda/10$ @ 633 nm
Clear aperture	Ø17 mm
Ring mount outer diameter	25.4 +0.0 / -0.12 mm
Surface quality	20-10 scratch & dig (MIL-PRF-13830B)
Parallelism	< 10 arcsec
AR coating	R < 0.5%
Nominal thickness of waveplate	0.2 - 1.2 mm
Laser damage threshold	>100 mJ/cm ² , 50 fsec pulse, 800 nm typical

Related Products

Dual Wavelength Plates of other wavelengths

Find more at EksmaOptics.com

High Precision Rotation Polarizer, Waveplate Mount 840-0186

Find more at EksmaOptics.com



Retardation and Wavelength	Catalogue number	Price, EUR
λ @ 800 nm + $\lambda/2$ @ 400 nm	463-4121	215
λ @ 800 nm + $\lambda/4$ @ 400 nm	463-4141	215
$\lambda/2$ @ 800 nm + λ @ 400 nm	463-4211	215
$\lambda/2$ @ 800 nm + $\lambda/2$ @ 400 nm	463-4221	215
$\lambda/2$ @ 800 nm + $\lambda/4$ @ 400 nm	463-4241	215
$\lambda/4$ @ 800 nm + λ @ 400 nm	463-4411	215
$\lambda/4$ @ 800 nm + $\lambda/2$ @ 400 nm	463-4421	215
$\lambda/4$ @ 800 nm + $\lambda/4$ @ 400 nm	463-4441	215

POLARIZATION PLANE ROTATORS

Features

- Made of crystalline quartz
- Intended to rotate a beam polarization plane strictly to an appropriate angle using circular birefringent effect

Compared to a waveplate, a rotator has an intrinsic advantage, being independent of rotation around its own optical axis. It needs no adjustment, only to be installed normal to incident radiation. A polarization plane rotator is normally used for the specific wavelength. It is only slightly dependent on ambient temperature.

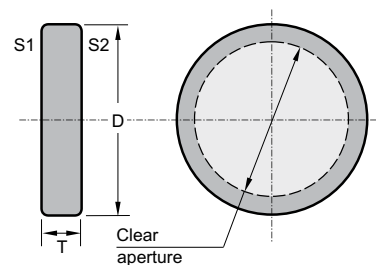

Polarization plane rotators for any wavelength from 200 to 2300 nm are available.

Specifications

Material	Single crystal quartz
Optical axis	Normal to faces S1, S2 of rotator
Clear aperture	Ø17 mm
Ring mount outer diameter	25.4 +0.0/-0.12 mm
Surface quality	20 – 10 scratch & dig (MIL-PRF-13830B)
Wavefront distortion	$\lambda/10$ @ 633 nm
Parallelism	< 10 arcsec
AR coating	R < 0.5%
Laser damage threshold	100 mJ/cm ² , 50 fsec pulse, 800 nm typical

Center wavelength, nm	Rotation angle of polarization plane, deg	AR coating range, nm	Catalogue number	Price, EUR
1030	45	1000-1060	470-4904	247
1030	90	1000-1060	470-4909	247
800	45	760-840	470-4804	224
800	90	760-840	470-4809	224
780	45	740-820	470-4784	224
780	90	740-820	470-4789	224
515	45	500-530	470-4514	224
515	90	500-530	470-4519	224
400	45	380-420	470-4044	224
400	90	380-420	470-4049	224
343	45	333-353	470-4344	224
343	90	333-353	470-4349	224
266	45	257-275	470-4264	282
266	90	257-275	470-4269	282
257	45	250-265	470-4254	282
257	90	250-265	470-4259	282

Related Products

Polarization plane rotators of other wavelengths

Find more at EksmaOptics.com

Kinematic Mirror Mount 840-0032, 840-0033

Find more at EksmaOptics.com



Kinematic Positioning Mount 840-0193

Find more at EksmaOptics.com



GROUP VELOCITY DELAY COMPENSATION PLATES

Features

- Made of calcite crystals
- Designed for different GVD compensation ranges
- Clear aperture Ø12 mm

Specifications

Material	Natural Calcite
Clear aperture	Ø12 mm
Ring mount outer diameter	25.4 +0.0 / -0.12 mm
Surface quality	40 – 20 scratch & dig (MIL-PRF-13830B)
Wavefront distortion	$\lambda/4$ @ 633 nm
Parallelism	<3 arc min
AR coating	R<0.5% 760–840 nm and R<1% at 380–420 nm R<0.5% at 500–530 + 1000–1060 nm

Group Velocity Delay (GVD) compensation plates are designed for specified ranges of time delay compensation between two different wavelength pulses with orthogonal polarizations. A compensation plate can be adjusted for the precisely desired delay by angular tuning – changing the angle of incidence (AOI) of the laser beams to the plate. The recommended AOI tuning range of the plate is from -10° to $+10^\circ$.

Standard GVD compensation plates are rectangular (full aperture 16×14 mm) with a clear aperture of Ø12 mm. They are supplied mounted into Ø25.4 mm (1") ring holders. Calcite

plates with clear apertures up to Ø20 mm can be produced on special requests.

The optical axis of calcite plates is at the particular orientation, which is not parallel to the faces of the plate. Thus walk-off effect for e-polarized beam and displacement of both beams at non-zero AOI should be considered in the actual application conditions. The plane of optical axis is parallel to the long 16 mm edge of the calcite plate and is marked on the ring holder.

Time delay compensators for custom wavelengths, specific delay values, as well as plates made of Alpha-BBO crystals are available on request.

Standard Calcite plates

For delay compensation between 800 nm ("o" polarization) and 400 nm ("e" polarization) pulses

Delay compensation range*	Coatings	Catalogue number	Price, EUR
246 – 507 fsec	BBAR @ 800+400 nm	225-2113	470
289 – 597 fsec	BBAR @ 800+400 nm	225-2114	470
347 – 716 fsec	BBAR @ 800+400 nm	225-2115	470

* GVD compensation range at Angle Of Incidence from -10° to $+10^\circ$.

Group velocity delay between 800 nm and 400 nm pulses in compensation plates at different angle of incidence. 400 nm pulse („e” pol) is faster than 800 nm pulse („o” pol).

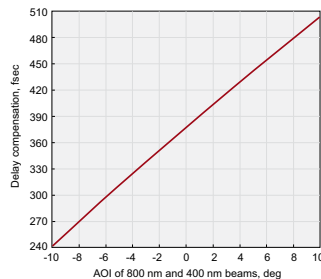

225-2113

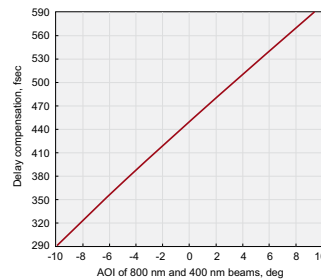

225-2114

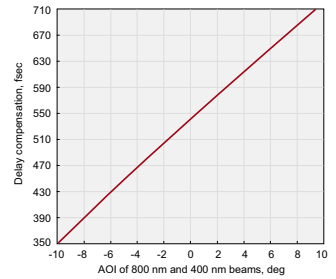

225-2115

Standard Calcite plates

For delay compensation between 1030 nm ("o" polarization) and 515 nm ("e" polarization) pulses

Delay compensation range*	Coatings	Catalogue number	Price, EUR
177 – 278 fs	BBAR @ 1030+515 nm	225-2210	470
236 – 370 fs	BBAR @ 1030+515 nm	225-2211	470
295 – 463 fs	BBAR @ 1030+515 nm	225-2212	470
378 – 593 fs	BBAR @ 1030+515 nm	225-2213	470

* GVD compensation range at angle of incidence from -10° to $+10^\circ$.

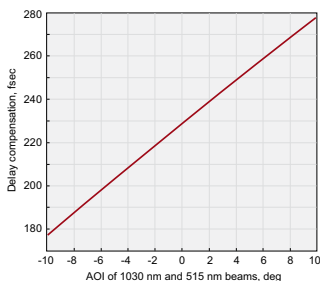

225-2210.

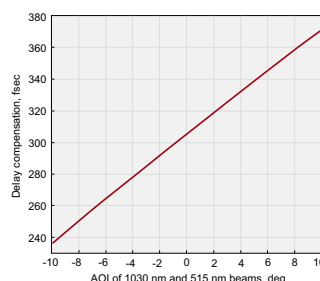

225-2211

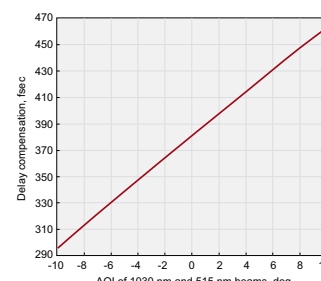

225-2212

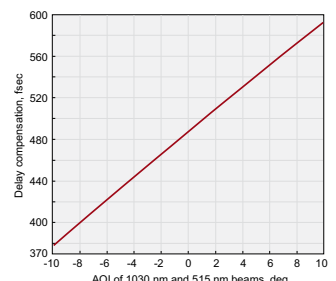

225-2213

CRYSTAL WINDOWS FOR WHITE LIGHT (CONTINUUM) GENERATION

The interaction of intense laser pulses with transparent media (the crystals with cubic structure are more effective) can result in vast spectral broadening, ranging from the infrared to the ultraviolet spectral region. This continuum or white-light generation is a well-established

phenomenon. Femtosecond laser induced white light has been the source of ultrashort coherent radiation for numerous applications: time-resolved broadband pump-probe spectroscopy, optical pulse compression, and optical parametric amplification.



Specifications

Material	undoped YAG, orientation [100]
Clear aperture	>90% of diameter
Diameter tolerance	+0.00 / -0.13 mm
Thickness tolerance	±0.2 mm
Surface quality	20–10 scratch & dig
Transmitted wavefront distortion	$\lambda/4 - \lambda/8$ @ 633 nm
Parallelism	<30 arcsec
Coating	uncoated

Standard YAG windows

Material	Diameter, mm	Thickness, mm	Transmitted wavefront distortion	Catalogue number	Price, EUR
YAG	12.7	1.0	$\lambda/8$	555-7121	230
YAG	12.7	2.0	$\lambda/8$	555-7122	230
YAG	12.7	3.0	$\lambda/8$	555-7123	240
YAG	12.7	4.0	$\lambda/8$	555-7124	240
YAG	12.7	5.0	$\lambda/8$	555-7125	245
YAG	12.7	6.0	$\lambda/8$	555-7126	250
YAG	12.7	8.0	$\lambda/8$	555-7128	260
YAG	12.7	10.0	$\lambda/8$	555-7129	270
YAG	25.4	1.0	$\lambda/4$	555-7251	295
YAG	25.4	2.0	$\lambda/4$	555-7252	295
YAG	25.4	3.0	$\lambda/4$	555-7253	315
YAG	25.4	4.0	$\lambda/4$	555-7254	315

Specifications

Material	sapphire, orientation c-cut [111]
Clear aperture	>90% of diameter
Diameter tolerance	+0.00 / -0.13 mm
Thickness tolerance	±0.2 mm
Surface quality	60–40 scratch & dig
Transmitted wavefront distortion	<1 λ @ 633 nm
Parallelism	<3 arcmin
Coating	uncoated

Standard Sapphire windows

Material	Diameter, mm	Thickness, mm	Transmitted wavefront distortion	Catalogue number	Price, EUR
Sapphire	12.7	0.5	1 λ	550-7120	29
Sapphire	12.7	1.0	1 λ	550-7121	28
Sapphire	12.7	2.0	1 λ	550-7122	28
Sapphire	12.7	3.0	1 λ	550-7123	28
Sapphire	12.7	4.0	1 λ	550-7124	30
Sapphire	12.7	5.0	1 λ	550-7125	32
Sapphire	12.7	6.0	1 λ	550-7126	33
Sapphire	12.7	8.0	1 λ	550-7128	55
Sapphire	20.0	0.5	1 λ	550-7200	39
Sapphire	20.0	1.0	1 λ	550-7201	39
Sapphire	20.0	1.5	1 λ	550-7215	39
Sapphire	20.0	2.0	1 λ	550-7202	39
Sapphire	25.4	0.5	1 λ	550-7250	50
Sapphire	25.4	1.0	1 λ	550-7251	50
Sapphire	25.4	2.0	1 λ	550-7252	50
Sapphire	25.4	3.0	1 λ	550-7253	50
Sapphire	25.4	4.0	1 λ	550-7254	50
Sapphire	25.4	5.0	1 λ	550-7255	55
Sapphire	25.4	6.0	1 λ	550-7256	77
Sapphire	25.4	8.0	1 λ	550-7258	88

Specifications

Material	single crystal CaF ₂ , orientation [001]
Clear aperture	>90% of diameter
Diameter tolerance	+0.00 / -0.13 mm
Thickness tolerance	±0.2 mm
Surface quality	40–20 scratch & dig
Transmitted wavefront distortion	$\lambda/4$ @ 633 nm
Parallelism	<1 arcmin
Coating	uncoated

Standard CaF₂ windows

Material	Diameter, mm	Thickness, mm	Transmitted wavefront distortion	Catalogue number	Price, EUR
CaF ₂	12.7	3.0	$\lambda/4$	531-5123	120
CaF ₂	12.7	4.0	$\lambda/4$	531-5124	140
CaF ₂	25.4	1.0	$\lambda/4$	531-5251	160
CaF ₂	25.4	2.0	$\lambda/4$	531-5252	160
CaF ₂	25.4	3.0	$\lambda/4$	531-5253	160
CaF ₂	25.4	4.0	$\lambda/4$	531-5254	180
CaF ₂	25.4	5.0	$\lambda/4$	531-5255	180

COMPACT VARIABLE LASER POWER ATTENUATOR – 990-0076

Features

- Attenuation range for reflected beam: 2% – 99.9%
- Attenuation range for transmitted beam: 0.1% – 98%
- Convenient 90° angle between reflected and transmitted beams
- No beam shift at exit



990-0076 Variable Attenuator incorporates a high-performance polarizing cube beamsplitter which reflects s-polarized light at 90° while transmitting p-polarized light. A rotatable $\lambda/2$ waveplate is placed in the incident polarized laser beam. The intensity ratio of the two outgoing beams may be continuously varied without alteration of other beam parameters by rotating the half waveplate. The intensity of either exit beam, or their intensity ratio, can be controlled over a wide dynamic range. Pure p-polarization could be selected for maximum transmission, or pure s-polarization for maximum reflection.

Specifications

Clear aperture diameter	10 mm
Polarization contrast	>1:1000
Weight	0.1 kg

Wavelength, nm	LIDT	Catalogue number	Price, EUR
343	3 J/cm ² @ 355 nm, 10 Hz, 10 ns	990-0076-343	825
355	3 J/cm ² @ 355 nm, 10 Hz, 10 ns	990-0076-355	825
515	6 J/cm ² @ 532 nm, 10 Hz, 10 ns	990-0076-515	800
532	6 J/cm ² @ 532 nm, 10 Hz, 10 ns	990-0076-532	800
1030	15 J/cm ² @ 1030 nm, 10 Hz, 10 ns	990-0076-1030	800
1064	15 J/cm ² @ 1064 nm, 10 Hz, 10 ns	990-0076-1064	800

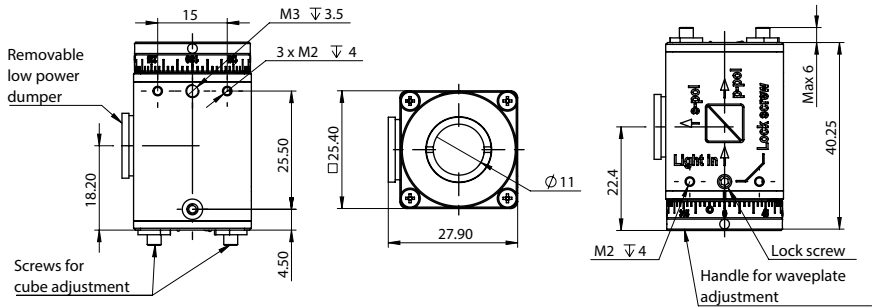

COMPACT VARIABLE LASER POWER ATTENUATORS – 990-0077, 990-0078

Features

- Attenuation range for transmitted beam:
 - Typical: 0.1% – 98%
 - For 257 nm and 266 nm: 1% – 94%
- Attenuation range for reflected beam
 - Typical: 2% – 99.9%
 - For 257 nm and 266 nm: 4% – 99%
- Extinction ratio: >1:1000
- Clear aperture:
 - 990-0077 – Ø17 mm
 - 990-0078 – Ø22 mm



990-0077 and 990-0078 Laser Power Attenuators

This manual variable attenuator series is designed to continuously attenuate linearly polarized laser beams. They feature precision opto-mechanics and high-LIDT optical components incorporated in a compact housing to ensure stable and reliable performance.

Attenuators are based on Brewster-type thin film polarizer fixed at 56° and a quartz half waveplate. The Polarizer's angle of incidence can be manually adjusted to get the best contrast or to manipulate the direction of the reflected s-polarized beam. The waveplate is housed in a 360° continuous rotation mount, which can be manually rotated to control the output power of the transmitted and reflected beams.

The intensity of either exit beam or their intensity ratio can be controlled over a wide dynamic range without alteration of other beam parameters. Pure p-polarization could be selected for maximum transmission, or pure s-polarization for maximum reflection. The s-polarization exit port can be blocked with a removable low-power dumper which absorbs laser power up to 5 W. External beam dumps are recommended for high-power applications.

990-0077 COMPACT VARIABLE ATTENUATORS WITH A CLEAR APERTURE OF Ø17 mm

Specifications

Clear aperture diameter	17 mm
Polarization contrast	>1:1000

Wavelength, nm	LIDT	Attenuation range (Tp)	Catalogue number	Price, EUR
257	1 J/cm ² @ 257 nm, 10 Hz, 10 ns	1% – 94%	990-0077-257	1090
266	1 J/cm ² @ 257 nm, 10 Hz, 10 ns	1% – 94%	990-0077-266	1090
343	3 J/cm ² @ 343 nm, 10 Hz, 10 ns	0.1% – 98%	990-0077-343	1015
355	3 J/cm ² @ 355 nm, 10 Hz, 10 ns	0.1% – 98%	990-0077-355	1015
515	5 J/cm ² @ 515 nm, 10 Hz, 10 ns	0.1% – 98%	990-0077-515	925
532	5 J/cm ² @ 532 nm, 10 Hz, 10 ns	0.1% – 98%	990-0077-532	925
1030	10 J/cm ² @ 1030 nm, 10 Hz, 10 ns	0.1% – 98%	990-0077-1030	975
1064	10 J/cm ² @ 1064 nm, 10 Hz, 10 ns	0.1% – 98%	990-0077-1064	975

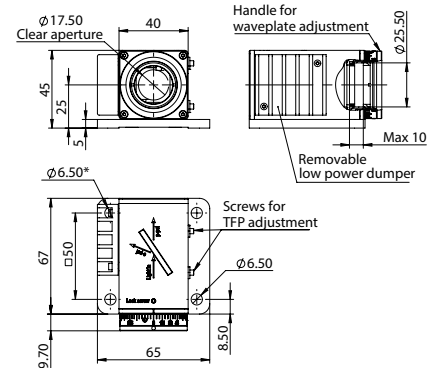

990-0078 COMPACT VARIABLE ATTENUATORS WITH A CLEAR APERTURE OF Ø22 mm

Specifications

Clear aperture diameter	22 mm
Polarization contrast	>1:1000

Wavelength, nm	LIDT	Attenuation range (Tp)	Catalogue number	Price, EUR
257	1 J/cm ² @ 257 nm, 10 Hz, 10 ns	1% – 94%	990-0078-257	1790
266	1 J/cm ² @ 257 nm, 10 Hz, 10 ns	1% – 94%	990-0078-266	1790
343	3 J/cm ² @ 343 nm, 10 Hz, 10 ns	0.1% – 98%	990-0078-343	1650
355	3 J/cm ² @ 355 nm, 10 Hz, 10 ns	0.1% – 98%	990-0078-355	1650
515	5 J/cm ² @ 515 nm, 10 Hz, 10 ns	0.1% – 98%	990-0078-515	1510
532	5 J/cm ² @ 532 nm, 10 Hz, 10 ns	0.1% – 98%	990-0078-532	1510
1030	10 J/cm ² @ 1030 nm, 10 Hz, 10 ns	0.1% – 98%	990-0078-1030	1625
1064	10 J/cm ² @ 1064 nm, 10 Hz, 10 ns	0.1% – 98%	990-0078-1064	1625

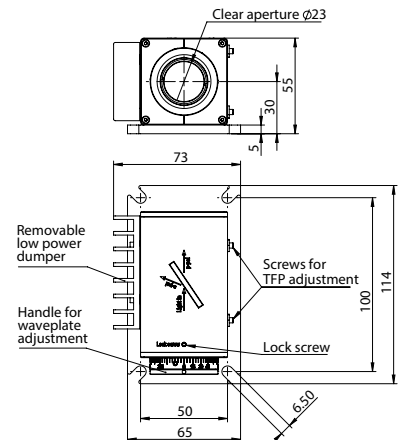

VARIABLE ATTENUATOR FOR FEMTOSECOND LINEARLY POLARIZED LASER BEAM 990-0070

Features

- Divides laser beam into two parallel beams of manually adjustable intensity ratio
- Large dynamic range
- Transmitted beam shift ~ 0.5 mm
- High Optical damage threshold
- Weight – 0.35 kg



Note: Movable base **820-0090**, Rod Holder **820-0050-02** and standard rod should be ordered separately.

This variable attenuator/beamsplitter consists of special design opto-mechanical Adapter and precision opto-mechanical Holder 840-0197. Two Thin Film Brewster type polarizers, which reflect s-polarized light while transmitting p-polarized light, are housed into Adapter. Quartz Half Waveplates are housed in rotating holder 840-0197.

The intensity ratio of those two beams may be continuously varied without alteration of other beam parameters by rotating the waveplate. The intensity of either exit

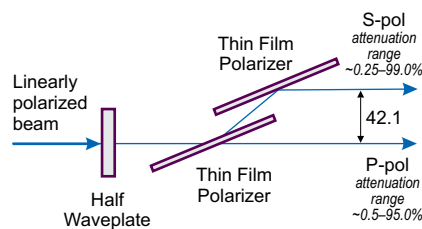

beam, or their intensity ratio, can be controlled over a wide dynamic range. P-polarization could be selected for maximum transmission, or high-purity s-polarization could be reflected when maximum attenuation of the transmitted beam takes place. The holder 840-0197 allows to adjust Angle Of Incidence of the Thin Film Brewster type polarizers by $\pm 2^\circ$ and to get the maximum polarization contrast.

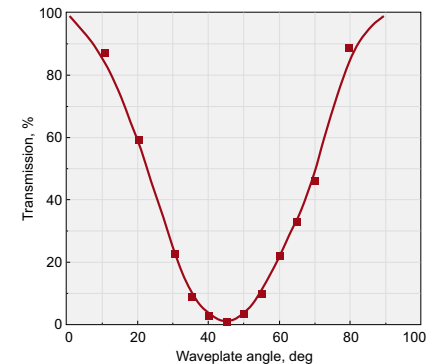

Specifications

Aperture diameter	17 mm
Damage threshold	>10 mJ/cm ² , 50 fs pulse at 800 nm, typical
for high power laser applications	>100 mJ/cm ² , 50 fs pulse at 800 nm, typical
Polarization Contrast (after 1st polarizer)	>1:200
Polarization Contrast (after 2nd polarizer)	>1:500

Wavelength, nm	Catalogue number	Price, EUR
257	990-0070-257	975
266	990-0070-266	975
343	990-0070-343	870
400	990-0070-400	770
390-410	990-0070-400B	920
515	990-0070-515	770
505-525	990-0070-515B	920
800	990-0070-800	770
780-820	990-0070-800B	920
1030	990-0070-1030	770
1010-1050	990-0070-1030B	920

Zero order optically contacted half waveplate is housed in rotating holder for high power femtosecond applications (Laser damage threshold: >10 mJ/cm², 50 fs pulse at 800 nm, typical).

For High Power Laser Applications

Wavelength, nm	Catalogue number	Price, EUR
257	990-0070-257H	1050
266	990-0070-266H	1050
343	990-0070-343H	945
400	990-0070-400H	845
390-410	990-0070-400HB	995
515	990-0070-515H	845
505-525	990-0070-515HB	995
800	990-0070-800H	845
780-820	990-0070-800HB	995
1030	990-0070-1030H	845
1010-1050	990-0070-1030HB	995

Zero Order Air-Spaced half waveplate is housed in rotating holder for high power femtosecond applications (Laser damage threshold: >100 mJ/cm², 50 fs pulse at 800 nm, typical).

Related Products

FemtoLine Zero Order Optically Contacted/Air-Spaced Plates

See page 26

FemtoLine Thin Film Laser Polarizers

See page 23

Neutral Density Filters

Find more at EksmaOptics.com

Motorized Variable Attenuator for Linearly Polarized Laser Beam 990-0070M

Find more at EksmaOptics.com



Beam dumps 990-0800, 990-0820

Find more at EksmaOptics.com



BROADBAND VARIABLE ATTENUATOR FOR FEMTOSECOND LASER PULSES 990-0070HBBi70

Features

- Divides laser beam into two parallel beams of manually adjustable intensity ratio
- Large dynamic range
- Transmitted beam shift ~ 2.6 mm
- High optical damage threshold

This variable attenuator/beamsplitter consists of a special design opto-mechanical adapter and a precision opto-mechanical holder 840-0197. Two thin film polarizers, operating at AOI=70° and reflecting s-polarized light while transmitting p-polarized light, are housed into the adapter. A quartz zero order air-spaced half waveplate is housed into the rotating holder 840-0197.

The intensity ratio of outgoing two parallel beams may be continuously varied without alteration of other beam parameters by rotating the waveplate. The intensity of the exit beam or

outgoing beams intensity ratio can be controlled over a wide dynamic range. P-polarized beam is transmitted straightly with a 2.6 mm shift and s-polarized beam (after 2 reflections) is parallel to the outgoing p-polarized beam, just separated by 28 mm. The 840-0197 holder allows to adjust angle of incidence of the thin film polarizers by ±2° and to achieve the maximum polarization contrast.



990-0070-800HBBi70

990-0070-800HBBi70M

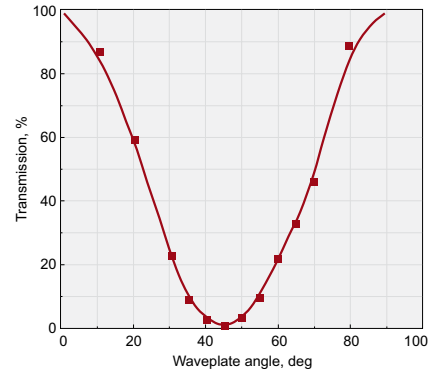
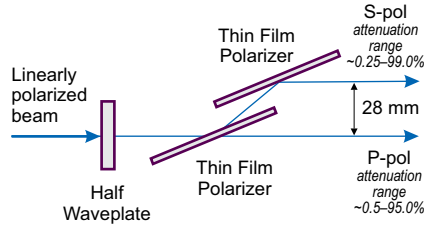

Specifications

Aperture diameter	12 mm
Operating bandwidth	100 nm
Damage threshold	50 mJ/cm ² pulsed at 800 nm, 50 fsec, 50 Hz
Polarization contrast (after 1st polarizer)	>1:200
Polarization contrast (after 2nd polarizer)	>1:500

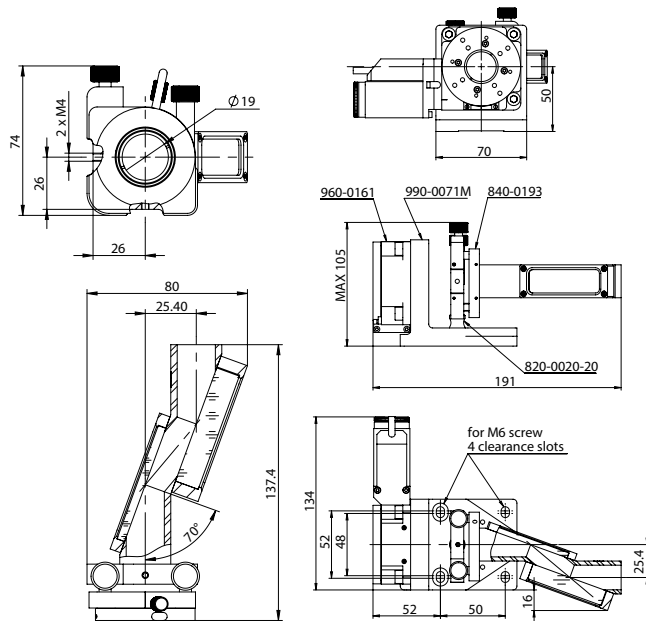

990-0070-800HBBi70

990-0070-800HBBi70M

Manual attenuators

Wavelength, nm	Catalogue number	Price, EUR
980-1080	990-0070-1030HBBi70	1300
750-850	990-0070-800HBBi70	1300
500-530	990-0070-515HBBi70	1300
333-353	990-0070-343HBBi70	1450
255-260	990-0070-257HBBi70	1450

Motorized attenuators

Wavelength, nm	Catalogue number *	Controller & power supply	Price, EUR
980-1080 nm	990-0070-1030HBBi70M	-	2180
980-1080 nm	990-0070-1030HBBi70M+CP	included	2925
750-850 nm	990-0070-800HBBi70M	-	2180
750-850 nm	990-0070-800HBBi70M+CP	included	2925
500-530 nm	990-0070-515HBBi70M	-	2180
500-530 nm	990-0070-515HBBi70M+CP	included	2925
333-353 nm	990-0070-343HBBi70M	-	2330
333-353 nm	990-0070-343HBBi70M+CP	included	3075
255-260 nm	990-0070-257HBBi70M	-	2330
255-260 nm	990-0070-257HBBi70M+CP	included	3075

* Items specified without the '+CP' suffix are delivered as opto-mechanical assemblies only. The '+CP' suffix designates configurations supplied with controller and power supply.

VARIABLE ATTENUATOR FOR FEMTOSECOND LINEARLY POLARIZED LASER BEAM 990-0071

Features

- Divides laser beam into two beams of manually adjustable intensity ratio separated by 68° angle
- Large dynamic range
- Transmitted beam shift ~0.5 mm
- High Optical damage threshold
- Weight – 0.25 kg



Note: Solid Base Height Extender **820-0210** and Standard Rod **820-0020-20** should be ordered separately

This variable attenuator/beamsplitter consists of special design opto-mechanical adapter for polarizer at 56° 840-0117A or 840-0118A and precision opto-mechanical holder 840-0197. Thin Film Brewster type polarizer, which reflect s-polarized light at 56° while transmitting p-polarized light, is housed into adapter for polarizer at 56°. Quartz Half Waveplates are housed in rotating holder 840-0197.

The intensity ratio of those two beams may be continuously varied without alteration of other beam parameters by rotating the

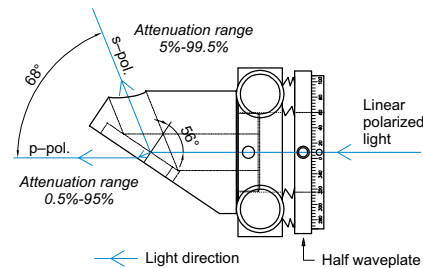

waveplate. The intensity of either exit beam, or their intensity ratio, can be controlled over a wide dynamic range. P-polarization could be selected for maximum transmission, or high-purity s-polarization could be reflected when maximum attenuation of the transmitted beam takes place. The holder 840-0197 allows to adjust Angle Of Incidence of the Thin Film Brewster type polarizer by $\pm 2^\circ$ and to get the maximum polarization contrast.

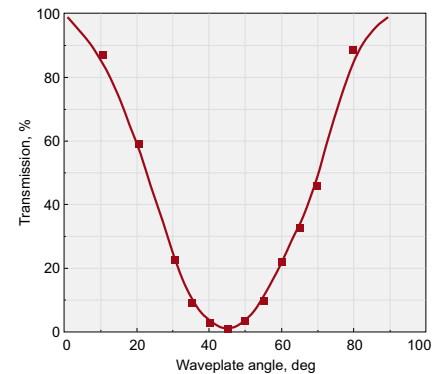

Specifications

Aperture diameter	10 mm
Damage threshold	>10 mJ/cm ² , 50 fs pulse at 800 nm, typical
for high power laser applications	>100 mJ/cm ² , 50 fs pulse, 800 nm typical
Polarization Contrast	>1:200

Wavelength, nm	Catalogue number	Price, EUR
257	990-0071-257	655
266	990-0071-266	655
343	990-0071-343	630
400	990-0071-400	580
390-410	990-0071-400B	680
515	990-0071-515	580
505-525	990-0071-515B	680
800	990-0071-800	580
780-820	990-0071-800B	680
1030	990-0071-1030	580
1010-1050	990-0071-1030B	680

Zero order optically contacted half waveplate is housed in rotating holder 840-0197 (laser damage threshold: >10 mJ/cm², 50 fs pulse at 800 nm, typical).

For High Power Laser Applications

Wavelength, nm	Catalogue number	Price, EUR
257	990-0071-257H	720
266	990-0071-266H	720
343	990-0071-343H	695
400	990-0071-400H	645
390-410	990-0071-400HB	745
515	990-0071-515H	645
505-525	990-0071-515HB	745
800	990-0071-800H	645
780-820	990-0071-800HB	745
1030	990-0071-1030H	645
1010-1050	990-0071-1030HB	745

Zero Order Air-Spaced half waveplate is housed in rotating holder 840-0197 (laser damage threshold: >100 mJ/cm², 50 fs pulse at 800 nm, typical).

Related Products

Neutral Density Filters

Find more at EksmaOptics.com

FemtoLine Zero Order Optically Contacted / Air-Spaced Plates

See page 26

FemtoLine Thin Film Laser Polarizers

See page 23

Motorized Variable Attenuator for Linearly Polarized Laser Beam 990-0071M

Find more at EksmaOptics.com



VARIABLE ATTENUATOR FOR FEMTOSECOND LASER PULSES 990-0072

Features

- Divides laser beam into two beams of manually adjustable intensity ratio separated by 68° angle
- Large dynamic range
- Transmitted beam shift ~1 mm
- High optical damage threshold
- Motorized version 990-0072M available online



This variable attenuator/beamsplitter consists of Polarizer Holder 840-0190-01 and Kinematic Mirror/Beamsplitter Mount 840-0056-12. UVFS Thin Film Brewster type polarizer diameter 50.8 mm, which reflect s-polarized light while transmitting p-polarized light, is housed into Beamsplitter Mount 840-0056-12. A quartz Zero Order (optically contacted) Half Waveplate diameter 25.4 mm (for femtosecond applications) or Zero Order Air-Spaced Half Waveplate (for high power applications) is housed in rotating polarizer holder 840-0190-01 and placed in the incident linearly polarized laser beam.

The intensity ratio of those two separated and different polarized beams may be continuously varied without alteration of other beam parameters by rotating the waveplate. The intensity of either exit beam, or their intensity ratio, can be controlled over a wide dynamic range. P-polarization could be selected for maximum transmission, or high-purity

s-polarization could be reflected when maximum attenuation of the transmitted beam takes place. The holder 840-0056-12 allows to adjust Angle Of Incidence of the Thin Film Brewster type polarizers by $\pm 4.5^\circ$ and to get the maximum extinction contrast. The mounts are on rods, rod holders and Movable Base 820-0090. The optical axis height from the table top can be adjusted in the range 78-88mm. Other height can be offered as custom changing the standard rods and rod holders into higher.

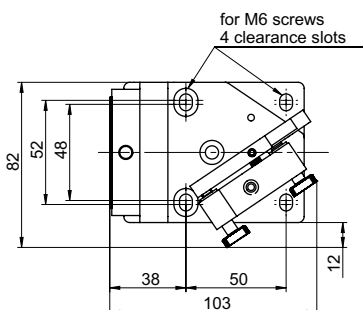
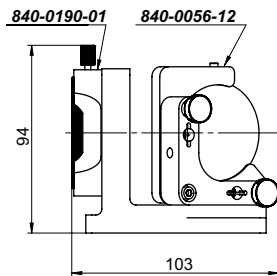
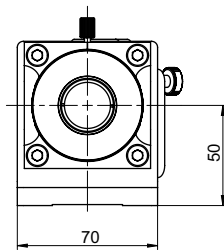
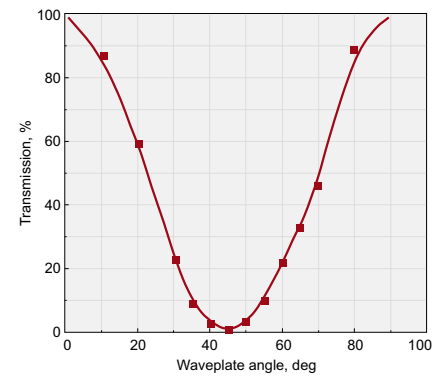

Specifications

Clear Aperture diameter	22 mm
Damage threshold	>10 mJ/cm ² , 50 fs pulse at 800 nm, typical
for high power applications	>100 mJ/cm ² , 50 fs pulse at 800 nm, typical
Polarization Contrast	>1:200
Transmitted beam shift	~ 1 mm
Weight	0.45 kg

Wavelength, nm	Catalogue number	Price, EUR
266	990-0072-266	980
343	990-0072-343	925
400	990-0072-400	895
515	990-0072-515	895
800	990-0072-800	910
780-820	990-0072-800B	1010
1030	990-0072-1030	920
1010-1050	990-0072-1030B	1010

A quartz Zero Order (optically contacted) Half Waveplate $\varnothing 25.4$ mm is housed in rotating holder 840-0190-01.

For High Power Laser Applications

Wavelength, nm	Catalogue number	Price, EUR
266	990-0072-266H	1115
343	990-0072-343H	1045
400	990-0072-400H	1030
515	990-0072-515H	1030
800	990-0072-800H	1045
780-820	990-0072-800HB	1145
1030	990-0072-1030H	1055
1010-1050	990-0072-1030HB	1145

A quartz Zero Order Air-Spaced Half Waveplate clear aperture $\varnothing 22$ mm is housed in rotating holder 840-0190-01.

Related Products

Neutral Density Filters

Find more at EksmaOptics.com

FemtoLine Zero Order Optically Contacted / Air-Spaced Plates

Find more at EksmaOptics.com

FemtoLine Thin Film Laser Polarizers

Find more at EksmaOptics.com

Motorized Variable Attenuator for Linearly Polarized Laser Beam 990-0072M

Find more at EksmaOptics.com

VARIABLE ATTENUATOR FOR FEMTOSECOND LASER PULSES 990-0073

Features

- Divides laser beam into two beams of manually adjustable intensity ratio separated by 68° angle
- Large dynamic range
- Transmitted beam shift ~1.4 mm
- High optical damage threshold



This variable attenuator/beamsplitter consists of Polarizer Holder 840-0180-A2 and Kinematic Mirror/Beamsplitter Mount 840-0056-13. UVFS Thin Film Brewster type polarizer Ø76.2 mm, which reflect s-polarized light while transmitting p-polarized light, is housed into Beamsplitter Mount 840-0056-13. A quartz Zero Order (optically contacted) Half Waveplate Ø40 mm or Zero Order Air-Spaced Half Waveplate Ø40 mm is housed in rotating polarizer holder 840-0180-A2 and placed in the incident linearly polarized laser beam. The intensity ratio of those two separated and different polarized beams may be continuously varied without alteration of other beam parameters by rotating the waveplate. The intensity of either exit beam, or their intensity ratio, can be controlled over a wide dynamic range. P-polarization could be selected for maximum transmission, or high-purity s-polarization could be reflected when maximum attenuation of the transmitted beam takes place.

The holder 840-0056-13 allows to adjust Angle Of Incidence of the Thin Film Brewster type polarizers by $\pm 4.5^\circ$ and to get the maximum extinction contrast. The mounts are on rods, rod holders and Movable Base 820-0090. The optical axis height from the table top can be adjusted in the range 92–98 mm. Other height can be offered as custom changing the standard rods and rod holders into higher.

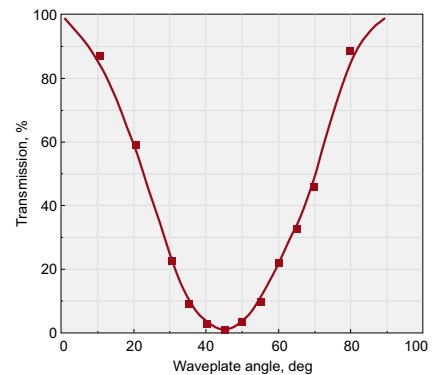

Specifications

Clear Aperture diameter	36 mm
Damage threshold	>10 mJ/cm ² , 50 fs pulse at 800 nm, typical
for high power applications	>100 mJ/cm ² , 50 fs pulse at 800 nm, typical
Polarization Contrast	>1:200
Transmitted beam shift	~ 1.4 mm
Weight	0.6 kg

Wavelength, nm	Catalogue number	Price, EUR
266	990-0073-266	1720
343	990-0073-343	1590
400	990-0073-400	1570
515	990-0073-515	1570
800	990-0073-800	1590
780-820	990-0073-800B	1820
1030	990-0073-1030	1645
1010-1050	990-0073-1030B	1880

A quartz Zero Order (optically contacted) Half Waveplate Ø40 mm is housed in rotating holder 840-0180-A2.

For High Power Laser Applications

Wavelength, nm	Catalogue number	Price, EUR
266	990-0073-266H	1820
343	990-0073-343H	1690
400	990-0073-400H	1670
515	990-0073-515H	1670
800	990-0073-800H	1690
780-820	990-0073-800HB	1920
1030	990-0073-1030H	1745
1010-1050	990-0073-1030HB	1980

A quartz Zero Order Air-Spaced Half Waveplate Ø40 mm is housed in rotating holder 840-0180-A2.

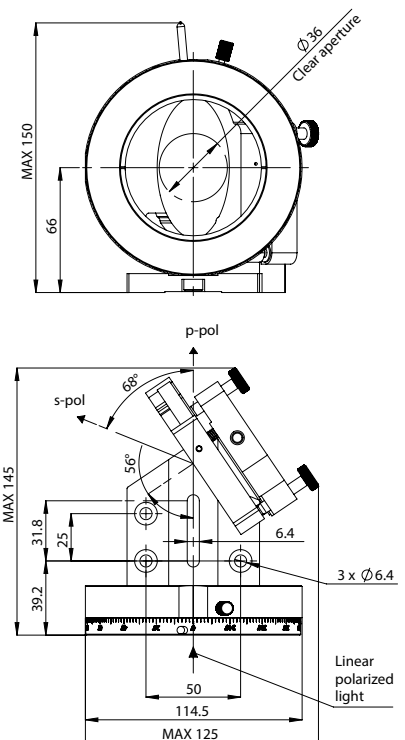

FIXED RATIO BEAM EXPANDERS FOR HIGH POWER LASERS

Features

- Designed for high power laser applications:
 - IBS-coated UV FS thin lenses
 - High total transmission: > 99%
 - Low GDD: relative pulse broadening < 20%
- AR-coated for: 1030 nm, 515 nm, 355 nm
- Fixed magnifications from 1.5X to 10X
- Divergence adjustment: non-rotating optics, sliding lens design

EKSMA Optics offers Galilean type beam expanders with thin UV FS lenses suitable for femtosecond applications. Fixed Ratio Beam Expanders are designed to increase the diameter of a collimated input high power laser beam to a larger collimated output

beam. Fixed Ratio Beam Expanders can be adjusted for the input beam divergence angle to obtain collimated, divergent or focused beam at the output. They feature non-rotating divergence adjustment by sliding lens design.

Specifications

Transmitted Wavefront Distortion (TWD)	$\lambda/6$ at 633nm	
Laser Damage Threshold	1030 nm	>0.5 J/cm ² , 200 fs pulse, 1 kHz
	515 nm	>0.4 J/cm ² , 200 fs pulse, 1 kHz
	343 nm	>0.3 J/cm ² , 200 fs pulse, 1 kHz
Input Thread	SMI external	
Output Thread	M43x0.5 external	
Mounting Options	M43x0.5, SMI, M27, M4, 8-32 UNC	

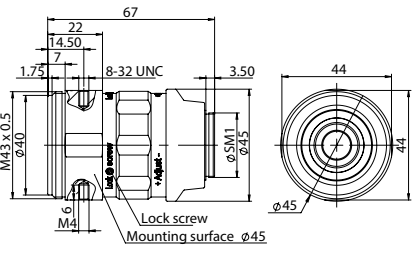

Model for 1.5X and 2X expanders

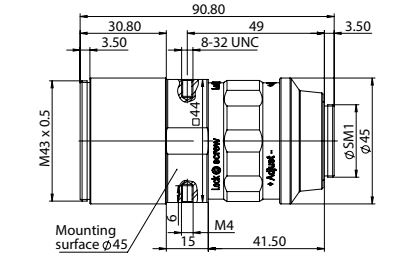

Model for 3X and 5X expanders

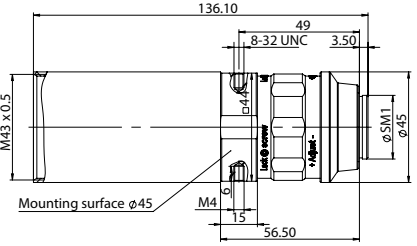

Model for 7.5X and 10X expanders

Designed for 1030 nm, coating R<0.1% @ 1000 – 1080 nm

Expansion ratio	Input clear aperture, mm	Output clear aperture, mm	Diffracted limited input beam diameter, mm	Focus range, m	GDD @ 1030 nm, fs ²	Catalogue number	Price, EUR
1.5X	11.0	22.8	11.0	4 – ∞	66	161-1.5X-1H	450
2X	11.0	22.8	9.0	2 – ∞	76	161-2X-1H	450
3X	11.0	34.5	9.0	2.5 – ∞	114	161-3X-1H	550
5X	10.0	34.5	4.5	1.7 – ∞	123	161-5X-1H	550
7.5X	8.0	36.0	3.5	3.5 – ∞	152	161-7.5X-1H	670
10X	8.0	36.0	3.0	3.2-∞	152	161-10X-1H	670

Designed for 515 nm, coating R<0.1% @ 500 – 535 nm

Expansion ratio	Input clear aperture, mm	Output clear aperture, mm	Diffracted limited input beam diameter, mm	Focus range, m	GDD @ 515 nm, fs ²	Catalogue number	Price, EUR
1.5X	11.0	22.8	11.0	4-∞	240	161-1.5X-2H	450
2X	11.0	22.8	9.0	2-∞	275	161-2X-2H	450
3X	11.0	34.5	9.0	2.5-∞	412	161-3X-2H	550
5X	10.0	34.5	4.5	1.7-∞	447	161-5X-2H	550
7.5X	8.0	36.0	3.5	3.5-∞	550	161-7.5X-2H	670
10X	8.0	36.0	3.0	3.2-∞	550	161-10X-2H	670

Designed for 343 nm, coating R<0.2% @ 340 – 355 nm

Expansion ratio	Input clear aperture, mm	Output clear aperture, mm	Diffracted limited input beam diameter, mm	Focus range, m	GDD @ 343nm, fs ²	Catalogue number	Price, EUR
1.5X	11.0	22.8	11.0	4-∞	432	161-1.5X-3H	530
2X	11.0	22.8	9.0	2-∞	495	161-2X-3H	530
3X	11.0	34.5	9.0	2.5-∞	741	161-3X-3H	630
5X	10.0	34.5	4.5	1.7-∞	803	161-5X-3H	630
7.5X	8.0	36.0	3.5	3.5-∞	988	161-7.5X-3H	750
10X	8.0	36.0	3.0	3.2-∞	988	161-10X-3H	750

FemtoLine Laser Crystals

Ti:Sapphire (TITANIUM DOPED SAPPHIRE – $Ti:Al_2O_3$) LASER LINE AND HARMONICS



Ti:Sapphire laser crystal is used as a gain medium for tunable lasers and femtosecond solid-state lasers. Lasers based on Ti:Sapphire crystal are mainly used to generate ultrashort – femtosecond pulses.

The lasing band of Ti:Sapphire is 660–1050 nm, while common pump wavelength is frequency doubled Nd:YAG laser line at 532 nm or Argon ion laser lines at 490–514 nm. The peak of emission in Ti:Sapphire is at 790–800 nm wavelength.

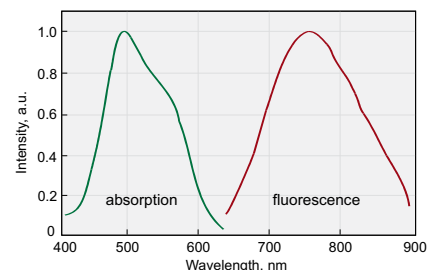

Material physical and laser properties

Chemical formula	$Ti^{3+}:Al_2O_3$
Crystal structure	Hexagonal
Lattice constants	$a=4.748, c=12.957$
Density	3.98 g/cm^3
Mohs hardness	9
Thermal conductivity	$0.11 \text{ cal}/(^{\circ}\text{C}\times\text{sec}\times\text{cm})$
Specific heat	0.10 cal/g
Melting point	$2050 \text{ }^{\circ}\text{C}$
Laser action	4-Level Vibronic
Fluorescence lifetime	$3.2 \mu\text{sec}$ ($T=300\text{K}$)
Tuning range	660–1050 nm
Absorption range	400–600 nm
Emission peak	795 nm
Absorption peak	488 nm
Refractive index	1.76 @ 800 nm

Standard product specifications

Orientation	optical axis C normal to rod axis
Ti_2O_3 concentration	0.03–0.25 wt %
Figure of Merit	>150
Size	up to 15 mm dia and up to 30 mm length
End configurations	flat/flat or Brewster/Brewster
End flatness	$\lambda/10$ @ 633 nm
Parallelism	10 arcsec
Surface finishing	10–5 scratch & dig
Wavefront distortion	$\lambda/4$ inch

Note: To inquire or order a finished Ti:Sa laser rod, please provide detailed specifications. Dopant concentration, size of crystal and end configuration are essential specifications.

FREQUENCY CONVERSION OF Ti:Sapphire LASER WAVELENGTHS

Frequency doubling and tripling allow access to the green, blue and ultraviolet spectral regions. While the frequency conversion by Optical Parametric Generation offers wide tuning range in the near-infrared spectral region, it is often sufficient to tune the Ti:sapphire wavelength for

tuning the OPO, rather than tuning the OPO itself, e.g. by actively affecting the phase-matching conditions. Further wavelength extension to mid infrared range is possible by Difference Frequency Generation employing signal and idler wavelength pulses obtained from OPO.

Crystals selection for Ti:Sapphire laser frequency conversion

Thin BBO crystals for SHG @ 800 nm	→	350 – 450 nm range
Thin BBO crystals for THG @ 800 nm	→	230 – 300 nm range
Thin BBO crystals for OPG/OPA @ pump 800 nm	→	1050 – 2300 nm range
Thin BBO crystals for OPG/OPA @ pump 400 nm	→	480 – 2300 nm range
AgGaS ₂ crystals for DFG	→	2500 – 12000 nm range

THIN BBO CRYSTALS FOR SHG AND THG OF Ti:Sapphire LASER WAVELENGTH



Free Standing BBO Crystals

The crystals down to 100 μm can be supplied as free standing crystals not attached to the support. However, ring mounts are highly recommended for safe handling of these thin crystals. Minimum aperture of free standing BBO is 5×5 mm, maximum aperture is 22×22 mm. The tolerance is $\pm 50 \mu\text{m}$ for crystals of thickness down to 300 μm and $\pm 20 \mu\text{m}$ for crystals of thickness down to 100 μm .

Protective Coatings for BBO crystals

P-protective coating – is a single or two layer antireflection coating made at specified wavelength range. Typical reflection values are $R < 2\%$ in the mid range, $R < 4\%$ at the edges. P coating is highly recommended for ultrashort pulse applications and features low dispersion and very high laser damage threshold.

Optically contacted crystals

BBO crystals less than 100 μm thickness can be supplied optically contacted on UV Fused Silica substrate sizes 10×10×1 mm or 12×12×2 mm. Other sizes of substrates are also available on request. Minimum aperture of optically contacted BBO is 5×5 mm, maximum aperture is 10×10 mm. The tolerance of crystal thickness is $\pm 10/-5$ microns.

Standard specifications of ultrathin BBO crystals

Flatness	$\lambda/8$ @ 633 nm
Parallelism	< 20 arcsec
Perpendicularity	< 5 arcmin
Angle tolerance	< 30 arcmin
Aperture tolerance	± 0.1 mm
Surface quality	10 – 5 scratch & dig (MIL-PRF-13830B)
Clear aperture	$> 90\%$ of full aperture
Laser damage threshold	> 200 GW/cm ² , 133 fsec pulse, 800 nm typical, 50 Hz

EKSMA OPTICS recommends the following thickness BBO crystals depending on application and fundamental wavelength pulse duration, assuming it is spectrum limited Gaussian pulse.

Application	Pulse duration, fs	Thickness, mm
Type 1, SHG @ 800 nm, $\Theta=29.2^\circ$, $\varphi=90^\circ$	10	0.05
	20	0.1
	50	0.2
	100	0.5
	200	1
Type 1, THG @ 800 nm, $\Theta=44.3^\circ$, $\varphi=90^\circ$	10	0.01
	20	0.02
	50	0.05
	100	0.1
	200	0.2

BBO FOR SHG @ 800 nm

BBO crystal. Thickness = 0.05 mm*

Aperture, mm	UV FS support size, mm	θ , deg	ϕ , deg	Coating	Catalogue number	Price, EUR
6×6	10×10×2	29.2	90	P/P @ 400-800 nm	BBO-600H	948
10×10	12×12×2	29.2	90	P/P @ 400-800 nm	BBO-1000H	1110

* All BBO crystals of thickness less than 100 μm are optically contacted onto UV FS support.
All crystals are mounted into open ring holders.

SHG BBO crystals. Thickness = 0.1 mm

Aperture, mm	θ , deg	ϕ , deg	Coating	Catalogue number	Price, EUR
6×6	29.2	90	P/P @ 400-800 nm	BBO-601H	505
10×10	29.2	90	P/P @ 400-800 nm	BBO-1001H	840

SHG BBO crystal. Thickness = 0.5 mm

Aperture, mm	θ , deg	ϕ , deg	Coating	Catalogue number	Price, EUR
6×6	29.2	90	P/P @ 400-800 nm	BBO-603H	440
10×10	29.2	90	P/P @ 400-800 nm	BBO-1003H	820

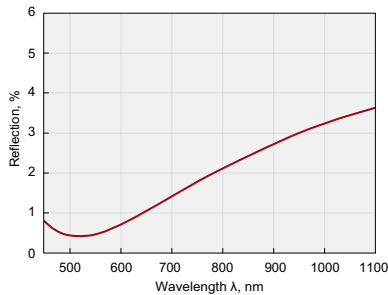

Typical P-coating for BBO SHG@800 nm application

SHG BBO crystal. Thickness = 0.2 mm

Aperture, mm	θ , deg	ϕ , deg	Coating	Catalogue number	Price, EUR
6×6	29.2	90	P/P @ 400-800 nm	BBO-602H	505
10×10	29.2	90	P/P @ 400-800 nm	BBO-1002H	840

SHG BBO crystal. Thickness = 1 mm

Aperture, mm	θ , deg	ϕ , deg	Coating	Catalogue number	Price, EUR
6×6	29.2	90	P/P @ 400-800 nm	BBO-604H	390
10×10	29.2	90	P/P @ 400-800 nm	BBO-1004H	795

SHG BBO crystal. Thickness = 2 mm

Aperture, mm	θ , deg	ϕ , deg	Coating	Catalogue number	Price, EUR
6×6	29.2	90	P/P @ 400-800 nm	BBO-605H	360
10×10	29.2	90	P/P @ 400-800 nm	BBO-1005H	850

Housing Accessories

Ring Holders for Nonlinear Crystals

Find more at
EksmaOptics.com



Positioning Mount 840-0199 for Nonlinear Crystal Housing

Find more at
EksmaOptics.com



BBO FOR THG @ 800 nm

BBO crystal. Thickness = 0.01 mm, optically contacted

Aperture, mm	UV FS support size, mm	θ , deg	φ , deg	Coating	Catalogue number	Price, EUR
6×6	10×10×2	44.3	90	P/P @ 400-800/266	BBO-606H	1020
10×10	12×12×2	44.3	90	P/P @ 400-800/266	BBO-1006H	1175

BBO crystal. Thickness = 0.02 mm, optically contacted

Aperture, mm	UV FS support size, mm	θ , deg	φ , deg	Coating	Catalogue number	Price, EUR
6×6	10×10×2	44.3	90	P/P @ 400-800/266	BBO-607H	1020
10×10	12×12×2	44.3	90	P/P @ 400-800/266	BBO-1007H	1175

BBO crystal. Thickness = 0.05 mm, optically contacted

Aperture, mm	UV FS support size, mm	θ , deg	φ , deg	Coating	Catalogue number	Price, EUR
6×6	10×10×2	44.3	90	P/P @ 400-800/266	BBO-608H	948
10×10	12×12×2	44.3	90	P/P @ 400-800/266	BBO-1008H	1110

THG BBO crystal. Thickness = 0.1 mm

Aperture, mm	θ , deg	φ , deg	Coating	Catalogue number	Price, EUR
6×6	44.3	90	P/P @ 400-800/266	BBO-609H	505
10×10	44.3	90	P/P @ 400-800/266	BBO-1009H	855

THG BBO crystal. Thickness = 0.2 mm

Aperture, mm	θ , deg	φ , deg	Coating	Catalogue number	Price, EUR
6×6	44.3	90	P/P @ 400-800/266	BBO-610H	505
10×10	44.3	90	P/P @ 400-800/266	BBO-1010H	855

THG BBO crystal. Thickness = 0.5 mm

Aperture, mm	θ , deg	φ , deg	Coating	Catalogue number	Price, EUR
6×6	44.3	90	P/P@400-800/266	BBO-611H	440
10×10	44.3	90	P/P@400-800/266	BBO-1011H	850

THG BBO crystal. Thickness = 1 mm

Aperture, mm	θ , deg	φ , deg	Coating	Catalogue number	Price, EUR
6×6	44.3	90	P/P @ 400-800/266	BBO-612H	390
10×10	44.3	90	P/P @ 400-800/266	BBO-1012H	840

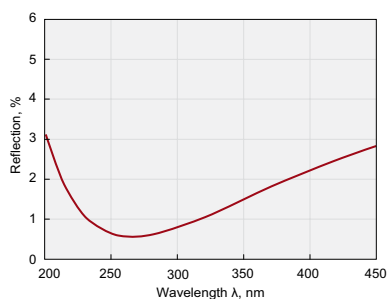

Typical coating for BBO THG@800 nm or SHG@532 nm applications (output face P@266 nm)

Related Products

Zero Order Dual Wavelength Plates

See page 27

Ring Holders for Nonlinear Crystals

Find more at EksmaOptics.com



Positioning Mount 840-0199 for Nonlinear Crystal Housing

Find more at EksmaOptics.com



FEMTOKITS FOR THIRD HARMONIC GENERATION OF FEMTOSECOND Ti:Sapphire LASER

Kits consist of set of components required for efficient third harmonic generation of femtosecond Ti:Sapphire laser. The schemes of the third harmonic generation in basic and extended Femtokits are presented below.

BASIC FEMTOKIT FK SERIES

The thickness of SHG BBO crystal, THG BBO crystal and group delay compensation plate is different in each kit and is optimal for certain pulse duration of fundamental harmonic to avoid harmonic pulses broadening.

Basic Femtokit FK series includes:

- Type 1 SHG BBO crystal with 6×6 mm aperture, P-coated @ 400–800 nm,
- Type 1 THG BBO crystal with 6×6 mm aperture, P-coated @ 400–800/266 nm,
- Calcite plate for group velocity delay compensation CP, AR coated @ 800+400 nm,
- Zero order dual waveplate W1, optically contacted, AR coated @ 800+400 nm,
- All above four components are mounted in to 1 inch ring holders for convenient handling.

Fundamental pulse duration	Basic FemtoKit FK Series		Basic Mounted FemtoKit FK Series	
	Catalogue number	Price, EUR	Catalogue number	Price, EUR
150 – 250 fsec	FK-800-200	1710	FK-800-200-M	2750
70 – 120 fsec	FK-800-100	1760	FK-800-100-M	2800
30 – 70 fsec	FK-800-050	2268	FK-800-050-M	3308
15 – 30 fsec	FK-800-020	2340	FK-800-020-M	3380

Non-standard kits with larger apertures of BBO crystals and thicknesses optimal for other pulse durations are available on request.



Mounted Femtokit FK Series

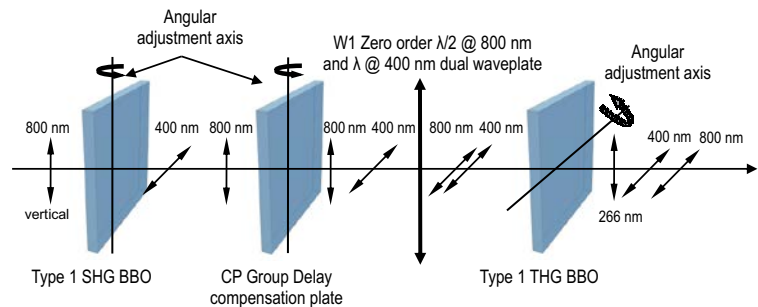

EXTENDED FEMTOKIT FKE SERIES

Up to 50% SHG conversion efficiency which was achieved in 0.5 mm SHG BBO crystal with Ti:Sapphire Super Spitfire laser operating at 1 kHz, 130 fs, 20-100 μ J @ 800 nm and effective beam diameter 0.9 mm.

THG efficiency was reached up to 8% from fundamental using FKE-800-100 Femtokit.

Extended Femtokit FKE series includes:

- All components from basic kit,
- Additional zero order waveplate W2, optically contacted, AR coated @ 800 nm,
- Harmonic Separator HS1 HR @ 266 nm and HT @ 800+400 nm at AOI=45 deg,
- Harmonic Separator HS2 HR @ 400 nm and HT @ 800 nm at AOI=45 deg,
- Laser mirror M1, HR at 800 nm at AOI=45 deg.

Fundamental pulse duration	Extended FemtoKit FKE Series		Extended Mounted FemtoKit FKE Series	
	Catalogue number	Price, EUR	Catalogue number	Price, EUR
150 – 250 fsec	FKE-800-200	2478	FKE-800-200-M	4367
120 – 150 fsec	FKE-800-130	2537	FKE-800-130-M	4417
30 – 70 fsec	FKE-800-050	3045	FKE-800-050-M	4925
15 – 30 fsec	FKE-800-020	3117	FKE-800-020-M	4997

Non-standard kits with larger apertures of BBO crystals and thicknesses optimal for other pulse durations are available on request.

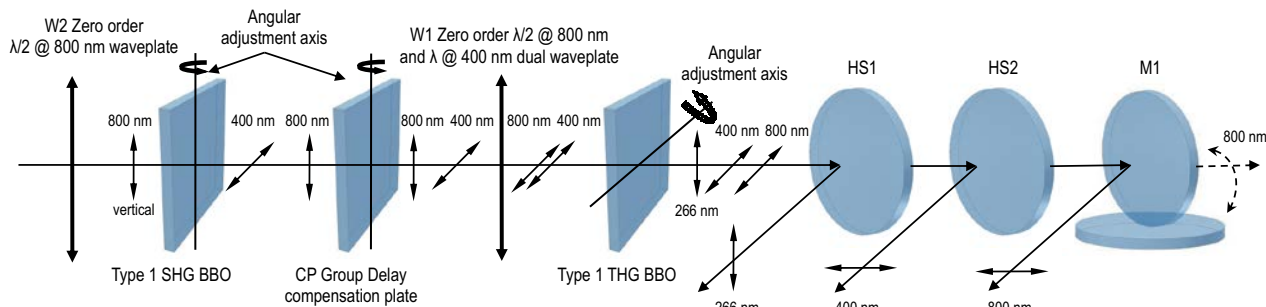

Extended Mounted Femtokit FKE Series

THIN AgGaS₂ CRYSTALS FOR DFG → 2.5 – 1.3 μm



Standard specifications

Flatness	$\lambda/6$ @ 633 nm
Parallelism	< 20 arcsec
Perpendicularity	< 10 arcmin
Angle tolerance	< 30 arcmin
Aperture tolerance	± 0.1 mm
Surface quality	10 – 5 scratch & dig (MIL-PRF-13830B)
Clear aperture	> 90% of full aperture

BBAR COATED AgGaS₂ CRYSTALS

BBAR coating – is multilayer dielectric antireflection coating made at specified wavelength range. Standard coating is designed to reduce reflection losses at input side at 1.1 – 2.6 micron range and output side at 2.6 – 11 micron range.

Typical reflection values are $R < 0.5\%$ in the mid range, and up to reflection values of uncoated crystal at the edges of given ranges. BBAR coating is designed to minimise dispersion of ultrashort pulses and also features high damage threshold.

Size, mm			Orientation		Coating	Application	Catalogue number	Price, EUR
W	H	L	θ	φ				
5	5	1	39	45	BBAR/BBAR @ 1.1-2.6 / 2.6-11 μm	DFG @ 1.2-2.4 μm → 2.4-11 μm	AGS-401H	1770
6	6	2	50	0	BBAR/BBAR @ 1.1-2.6 / 2.6-11 μm	DFG @ 1.2-2.4 μm → 2.4-11 μm	AGS-402H	2375
5	5	0.4	34	45	BBAR/BBAR @ 3-6 / 1.5-3 μm	SHG @ 3-6 μm, Type 1	AGS-403H	2040
5	5	0.4	39	45	BBAR/BBAR @ 1.1-2.6 / 2.6-11 μm	DFG @ 1.2-2.4 μm → 2.4-11 μm	AGS-404H	2040
8	8	0.4	39	45	BBAR/BBAR @ 1.1-2.6 / 2.6-11 μm	DFG @ 1.2-2.4 μm → 2.4-11 μm	AGS-801H	4080
8	8	1	39	45	BBAR/BBAR @ 1.1-2.6 / 2.6-11 μm	DFG @ 1.2-2.4 μm → 2.4-11 μm	AGS-802H	3670

Crystals are mounted into open ring holders.

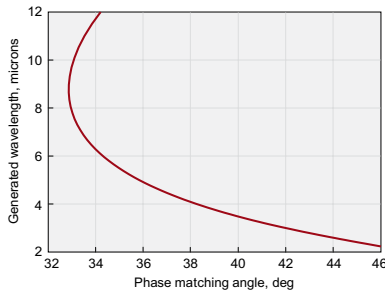

Type 1 DFG ($e-o=e$) in AGS. DFG of signal and idler generated in BBO pumped at 800 nm

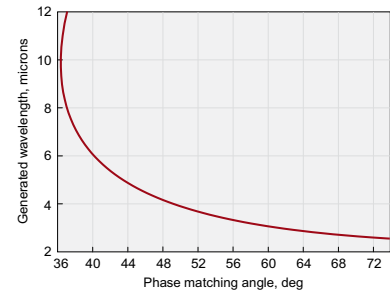

Type 2 DFG ($e-o=e$) in AGS. DFG of signal and idler generated in BBO pumped at 800 nm

Housing Accessories

Ring Holders for Nonlinear Crystals

Find more at EksmaOptics.com



Positioning Mount 840-0199 for Nonlinear Crystal Housing

Find more at EksmaOptics.com



Yb:KGW AND Yb:KYW CRYSTALS LASER LINES AND HARMONICS



Yb:KGW and Yb:KYW crystals have broad emission bandwidths and are used as lasing materials to generate ultrashort (~100 – 200 fs) high power pulses. Direct pump of Yb:KGW/KYW crystals with laser diodes operating at 981 nm supports compact laser systems. Yb:KGW/KYW laser generates

pulses at 1023 – 1060 nm wavelength range. Also Yb:KGW and Yb:KYW can be used as ultrashort pulse amplifiers. We believe that Yb:KGW and Yb:KYW are some of the best materials for high power thin disk lasers generating femtosecond pulses.

Features

- High absorption coefficient at 981 nm
- High stimulated emission cross section
- Low laser threshold
- Extremely low quantum defect $\lambda_{pump} / \lambda_{se}$
- Broad polarized output at 1023–1060 nm
- High slope efficiency with diode pumping (~ 60%)
- High Yb doping concentration

Custom manufacturing capabilities

- Various shapes (slabs, rods, cubes, disks)
- Different dopant levels
- Diversified coatings
- Attractive prices for introductory quantities to OEMs

Properties of Yb:KGW and Yb:KYW

Name	Yb:KGW	Yb:KYW
Yb ³⁺ concentration	0.5–5%	0.5–100%
Crystal structure	monoclinic	monoclinic
Point group	C2/c	C2/c
Lattice parameters	a=8.095 Å, b=10.43 Å, c=7.588 Å, β=94.43°	a=8.05 Å, b=10.35 Å, c=7.54 Å, β=94°
Thermal expansion	$\alpha_a=4 \times 10^{-6} / ^\circ\text{C}$, $\alpha_b=3.6 \times 10^{-6} / ^\circ\text{C}$, $\alpha_c=8.5 \times 10^{-6} / ^\circ\text{C}$	–
Thermal conductivity	$K_a=2.6 \text{ W/mK}$, $K_b=3.8 \text{ W/mK}$, $K_c=3.4 \text{ W/mK}$	–
Density	7.27 g/cm ³	6.61 g/cm ³
Mohs' hardness	4–5	4–5
Melting temperature	1075 °C	–
Transmission range	0.35–5.5 μm	0.35–5.5 μm
Refractive indices (λ=1.06 μm)	$n_g=2.037$, $n_p=1.986$, $n_m=2.033$	–
Thermo-optic coefficients @ 1064 nm	$\partial n_p / \partial T = -15.7 \times 10^{-6} \text{ K}^{-1}$ $\partial n_m / \partial T = -11.8 \times 10^{-6} \text{ K}^{-1}$ $\partial n_g / \partial T = -17.3 \times 10^{-6} \text{ K}^{-1}$	<i>For 20% Yb:KYW</i> $\partial n_p / \partial T = -13.08 \times 10^{-6} \text{ K}^{-1}$ $\partial n_m / \partial T = -7.61 \times 10^{-6} \text{ K}^{-1}$ $\partial n_g / \partial T = -11.83 \times 10^{-6} \text{ K}^{-1}$
Laser wavelength	1023–1060 nm	1025–1058 nm
Fluorescence lifetime	0.3 ms	0.3 ms
Stimulated emission cross section (E a)	$2.6 \times 10^{-20} \text{ cm}^2$	$3 \times 10^{-20} \text{ cm}^2$
Absorption peak and bandwidth	$\alpha_a=26 \text{ cm}^{-1}$, λ=981 nm, Δλ=3.7 nm	$\alpha_a=40 \text{ cm}^{-1}$, λ=981 nm, Δλ=3.5 nm
Absorption cross section	$1.2 \times 10^{-19} \text{ cm}^2$	$1.33 \times 10^{-19} \text{ cm}^2$
Lasing threshold	35 mW	70 mW
Stark levels energy (in cm ⁻¹) of the ² F _{5/2} manifolds of Yb ³⁺ @ 77K	10682, 10471, 10188	10695, 10476, 10187
Stark levels energy (in cm ⁻¹) of the ² F _{7/2} manifolds of Yb ³⁺ @ 77K	535, 385, 163, 0	568, 407, 169, 0

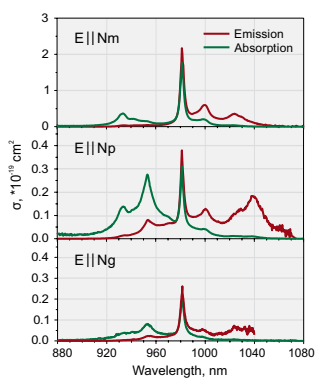

Absorption and stimulated emission cross sections of Yb:KYW

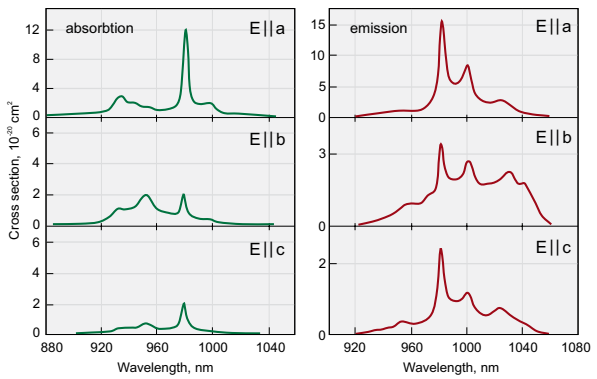

Absorption and emission spectrae of Yb(5%):KGW

BBO AND LBO CRYSTALS FOR Yb:KGW/KYW FREQUENCY CONVERSION

EKSMA OPTICS recommends the following thickness BBO and LBO crystals for Yb:KGW/KYW frequency conversion depending on fundamental wavelength pulse duration, assuming it is spectrum limited Gaussian pulse.

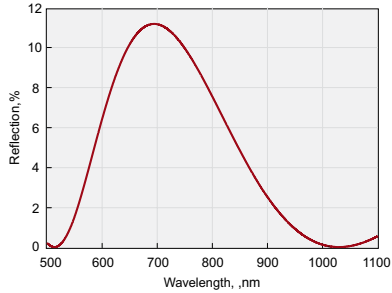

Typical AR@1030+515 nm coating for LBO or BBO SHG@1030 nm application

LBO FOR SHG @ 1030 nm

SHG LBO crystals. Type 1, Thickness = 0.9 mm

Aperture, mm	θ , deg	φ , deg	Coating	Catalogue number	Price, EUR
6×6	90	13.8	AR/AR @ 515+1030 nm	LBO-601H	515
10×10	90	13.8	AR/AR @ 515+1030 nm	LBO-1001H	650

SHG LBO crystals. Type 1, Thickness = 2.8 mm

Aperture, mm	θ , deg	φ , deg	Coating	Catalogue number	Price, EUR
6×6	90	13.8	AR/AR @ 515+1030 nm	LBO-603H	545
10×10	90	13.8	AR/AR @ 515+1030 nm	LBO-1003H	1035

BBO FOR SHG @ 1030 nm

SHG BBO crystals. Type 1, Thickness = 0.5 mm

Aperture, mm	θ , deg	φ , deg	Coating	Catalogue number	Price, EUR
6×6	23.4	90	AR/AR @ 515+1030 nm	BBO-651H	495
10×10	23.4	90	AR/AR @ 515+1030 nm	BBO-1051H	760

SHG BBO crystals. Type 1, Thickness = 1.5 mm

Aperture, mm	θ , deg	φ , deg	Coating	Catalogue number	Price, EUR
6×6	23.4	90	AR/AR @ 515+1030 nm	BBO-653H	475
10×10	23.4	90	AR/AR @ 515+1030 nm	BBO-1053H	795

BBO FOR THG @ 1030 nm

Aperture, mm	Thickness, mm	θ , deg	φ , deg	Coating	Catalogue number	Price, EUR
6×6	0.15	32.5	90	AR/AR @ 1030+515/343 nm	BBO-631H	725
6×6	0.25	32.5	90	AR/AR @ 1030+515/343 nm	BBO-632H	665
6×6	0.4	32.5	90	AR/AR @ 1030+515/343 nm	BBO-633H	605
6×6	0.55	32.5	90	AR/AR @ 1030+515/343 nm	BBO-634H	540

BBO crystals

Pulse duration	BBO SHG @ 1030 nm	BBO THG @ 1030 nm	BBO 4HG @ 1030 nm
50 fs	0.5 mm	0.15 mm	0.1 mm
100 fs	1 mm	0.25 mm	0.15 mm
150 fs	1.5 mm	0.4 mm	0.2 mm
200 fs	2 mm	0.55 mm	0.3 mm

LBO crystals

Pulse duration	LBO SHG @ 1030 nm
50 fs	0.9 mm
100 fs	1.9 mm
150 fs	2.8 mm
200 fs	3.7 mm

Note:

LBO crystals can be supplied with Clear Aperture up to \varnothing 50 mm.

SHG LBO crystals. Type 1, Thickness = 1.9 mm

Aperture, mm	θ , deg	φ , deg	Coating	Catalogue number	Price, EUR
6×6	90	13.8	AR/AR @ 515+1030 nm	LBO-602H	460
10×10	90	13.8	AR/AR @ 515+1030 nm	LBO-1002H	815

SHG LBO crystals. Type 1, Thickness = 3.7 mm

Aperture, mm	θ , deg	φ , deg	Coating	Catalogue number	Price, EUR
6×6	90	13.8	AR/AR @ 515+1030 nm	LBO-604H	465
10×10	90	13.8	AR/AR @ 515+1030 nm	LBO-1004H	895

SHG BBO crystals. Type 1, Thickness = 1.0 mm

Aperture, mm	θ , deg	φ , deg	Coating	Catalogue number	Price, EUR
6×6	23.4	90	AR/AR @ 515+1030 nm	BBO-652H	430
10×10	23.4	90	AR/AR @ 515+1030 nm	BBO-1052H	785

SHG BBO crystals. Type 1, Thickness = 2.0 mm

Aperture, mm	θ , deg	φ , deg	Coating	Catalogue number	Price, EUR
6×6	23.4	90	AR/AR @ 515+1030 nm	BBO-654H	480
10×10	23.4	90	AR/AR @ 515+1030 nm	BBO-1054H	835

BBO FOR 4HG @ 1030 nm

Aperture, mm	Thickness, mm	θ , deg	φ , deg	Coating	Catalogue number	Price, EUR
6×6	0.1	50	90	P/P @ 515/257 nm	BBO-641H	600
6×6	0.15	50	90	P/P @ 515/257 nm	BBO-642H	570
6×6	0.2	50	90	P/P @ 515/257 nm	BBO-643H	550
6×6	0.3	50	90	P/P @ 515/257 nm	BBO-644H	535



We Solve Optical Challenges



www.eksmaoptics.com

Dvarcioniu st. 2B
10233 Vilnius, Lithuania
info@eksmaoptics.com
Tel.: +370 5 272 99 00