

## 810-0100

## ANGLE BRACKET



The main use of 810-0100 mini bracket is mounting of 860-0010 translators for three axes positioning. The 810-0100 mini bracket has two M6 tapped holes on 25 mm centers.

Finish: black oxidized steel.

Code	Weight, kg	Price, EUR
810-0100	0.75	19

## Complementary Products

Code	Page
860-0010	8.104

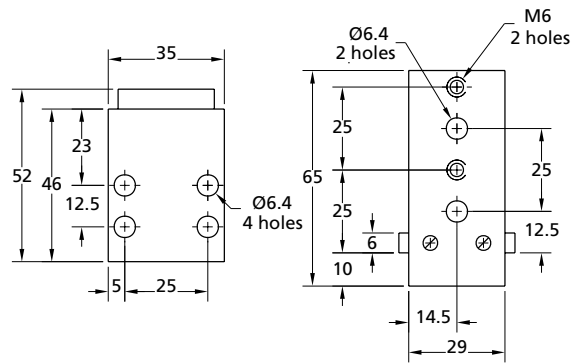

## 810-0110

## ANGLE BRACKET

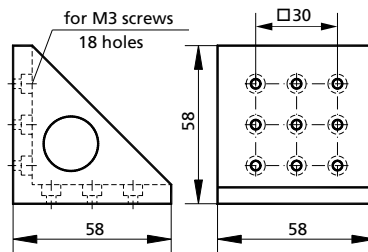

860-0051 XYZ

## Complementary Products

Code	Page
860-0051	8.107

- Black anodized aluminium
- Designed to be used with:
  - Translation Stages 860-0051

Code	Weight, kg	Price, EUR
810-0110	0.13	71

## 810-0112

## ANGLE BRACKET

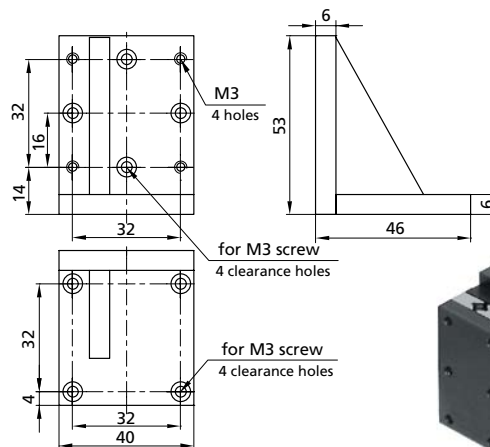

860-0096 XYZ

- Black anodized aluminium
- Designed to be used with:
  - Aluminium Ball Bearing Stages 860-0096
  - Motorized Translation Stage 970-0080

Code	Weight, kg	Price, EUR
810-0112	0.1	31

## Complementary Products

Code	Page
860-0096	8.124
970-0080	8.187