

970-0080

MOTORIZED TRANSLATION STAGE

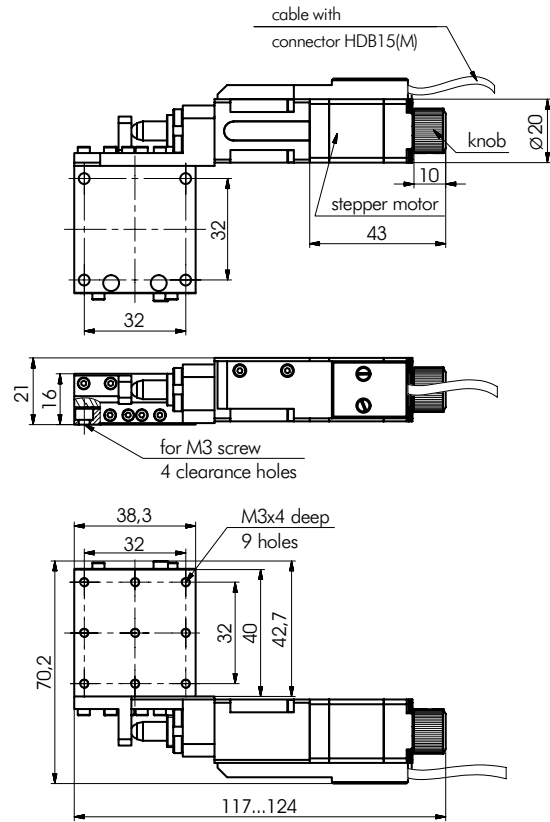

- Compact design
- Precise movement
- 13 mm travel range
- X-Y-Z direct stacking
- Motorized Actuator 970-0050-15
- Lockable
- Black anodized aluminium

SPECIFICATIONS

Travel range	13 mm
Resolution	1.25 μ m
Lead screw pitch	0.25 mm
Weight	0.25 kg
Optocoupler end limit switches	2 per actuator
Switch polarity	pushed is open

Code	Price, EUR
970-0080	490



970-0080 XY

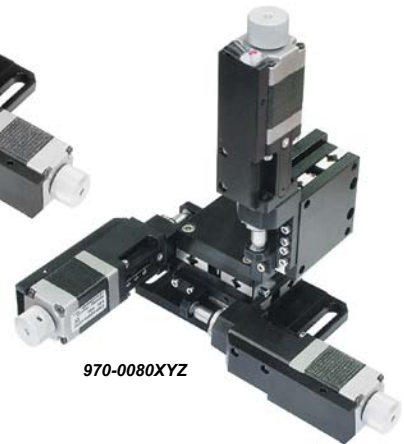

970-0080XYZ

Motorized Translation Stage 970-0085 with motorized actuator 970-0067-15 is available.



For product data sheet please visit www.eksmaoptics.com.

Complementary Products



820-0135-04

Universal base plate for stacking the translation stages to optical tables or to another stages.

See page 8.38

RECOMMENDED CONTROLLERS



980-0040-USB
see page 8.189



980-0030-RS232
see page 8.188

OPTICAL TABLES

BRACKETS & RAILS

BASE MOUNTS & ACCESSORIES

OPTICAL MOUNTS

OPTICAL POSITIONERS

BASE POSITIONERS

TRANSLATION & ROTATION STAGES

ADJUSTMENT SCREWS

MOTORIZED POSITIONERS