

960-0070-03 **MOTORIZED TRANSLATION STAGES** **new**

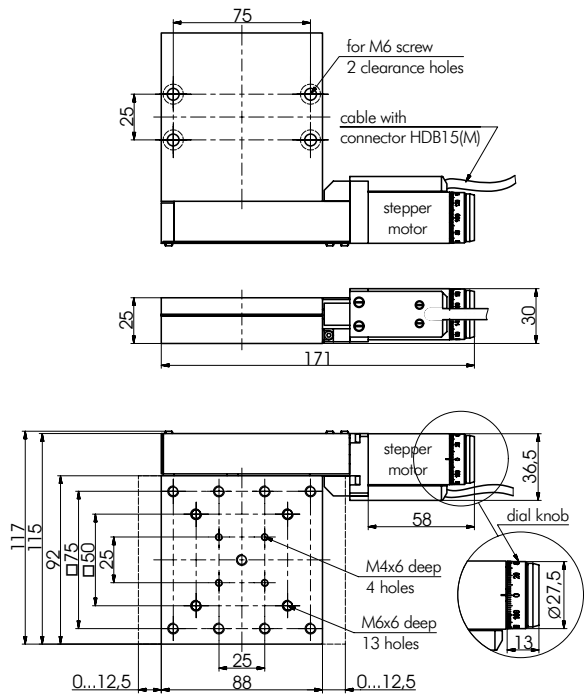

960-0070-03BS1 / 960-0070-03LS

960-0070-03 models are made with solid platform. 960-0070-03BS1, unlike the 960-0070-03LS, is designed for high-speed movement. Used ball bearing lead screw makes movement fast and smooth.



“Mirror” version of 960-0070-03BS1 and 960-0070-03LS



960-0070-03BS1-M / 960-0070-03LS-M

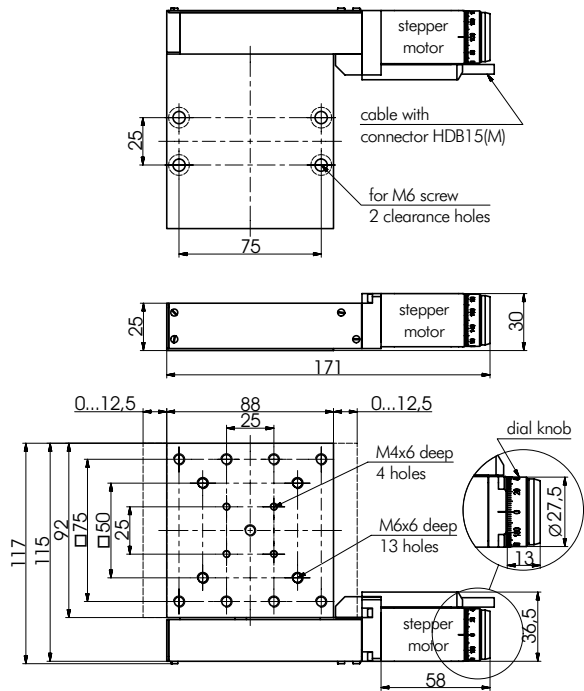

- OPTICAL TABLES
- BRACKETS & RAILS
- BASE MOUNTS & ACCESSORIES
- OPTICAL MOUNTS
- OPTICAL POSITIONERS
- BASE POSITIONERS
- TRANSLATION & ROTATION STAGES
- ADJUSTMENT SCREWS
- MOTORIZED POSITIONERS

SPECIFICATIONS

Model	960-0070-03BS1	960-0070-03LS
Travel range, mm	25	
Resolution in full step, μm	5	1.25
in 1/8 step, μm	0.625	0.156
Ball screw pitch, mm	1	-
Lead screw pitch, mm	-	0.25
Repeatability, μm	1.5	1
Maximum speed, mm/s	25	6
Maximum load capacity		
Horizontal, kg	30	
Vertical, kg	7	
Limit switches	2 pc mechanical	
Cable	1.6 m length	
Motor connector	HDB15(M)	
Stepper motor	28	
Weight, kg	0.8	
Price, EUR	583	478

RECOMMENDED CONTROLLERS



960-0070-03 XYZ 3 axis translation

Angle Bracket 810-0115



Angle bracket 810-0115 is used to transform "horizontal" translators into vertical ones, result is 960-0070-03 XYZ 3 axis translation system.

See page 8.26 for details.

Complementary Products

Code	Page
810-0115	8.26
820-0136	8.36

