

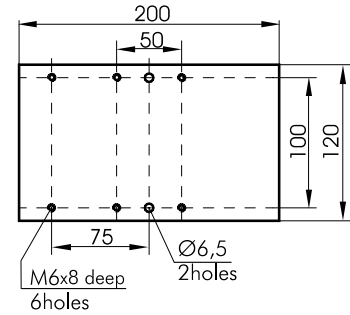

SPECIFICATIONS

Travel range	95 mm
Height:	
Min.	89 mm
Max.	184 mm
Lead screw pitch	1 mm
Top and bottom plates parallel to	1 mm
Load capacity	8 kg (depending on motor and controller)
Material	black anodized aluminium
Supply voltage	36 V
Motor connector	DB9(M)
Motor	5918
Weight	4.3 kg
Mechanical end limit switches	2
Switch polarity	pushed is closed

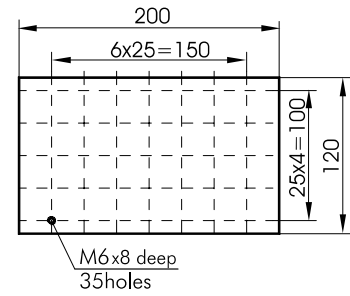
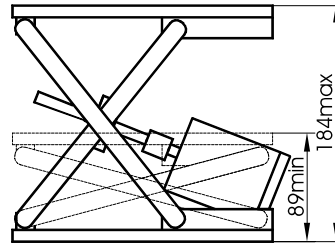

RECOMMENDED CONTROLLERS



980-0040-USB
see page 8.189



980-0030-RS232
see page 8.188

940-0210 MOTORIZED VERTICAL STAGE

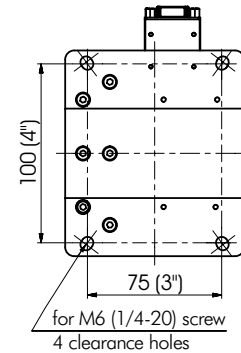
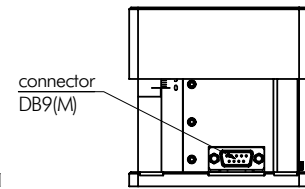
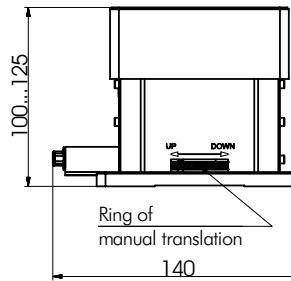

SPECIFICATIONS

Travel range	25 + 1 mm
Resolution in full step	5 µm
Resolution in 1/8 step	0.625 µm
Lead screw pitch	1 mm
Maximum speed	20 mm/sec
Load capacity	8 kg
Unidirectional repeatability	1 µm
Bi-directional repeatability	2 µm
Motor	2 phase stepper actuator
Limit switch	2, optocoupler
Switch polarity	pushed is open
Weight	2.2 kg

- High precision
- High speed (up to 20 mm/sec)
- Loads up to 8 kg
- Compact design
- Direct drive actuator
- Stacks directly with 960-0130, 960-0150 rotators and 960-0070-02 translators

RECOMMENDED CONTROLLERS



980-0040-USB
see page 8.189



980-0030-RS232
see page 8.188

Code	Price, EUR
940-0210	1515

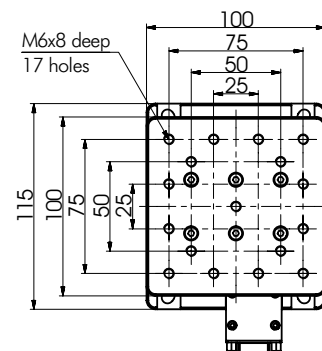

OPTICAL TABLES
BRACKETS & RAILS
BASE MOUNTS & ACCESSORIES
OPTICAL MOUNTS
OPTICAL POSITIONERS
BASE POSITIONERS
TRANSLATION & ROTATION STAGES
ADJUSTMENT SCREWS
MOTORIZED POSITIONERS