

940-0070

MOTORIZED TWO AXES TRANSLATION OPTICAL MOUNT



- **1" optics mounts**
- **Limit switch: optoelectronic couple**
- **Designed to use with microscope**
- **Black anodized aluminium**

The 940-0070 is made of 840-0207 XY Translation Mount and 970-0060 Compact Motorized Actuator.

Code	Price, EUR
940-0070	744

SPECIFICATIONS

Resolution:	
in full step	1.25 µm
in 1/8 step	0.156 µm
XY translation range	±2 mm
Lead screw pitch	0.25 mm
Optics diameter	25.4 mm
Clear aperture	23 mm
Installed actuators	2 x 970-0060
Cable	1.2 m length cable included
Motor connector	HDB15(M) (wiring diagram)
Weight	0.8 kg
Optocoupler end limit switches	2 per actuator
Switch polarity	pushed is open

DC motor base actuators are available on request.

Complementary Products

Code	Page
840-0207	8.95
970-0060	8.184

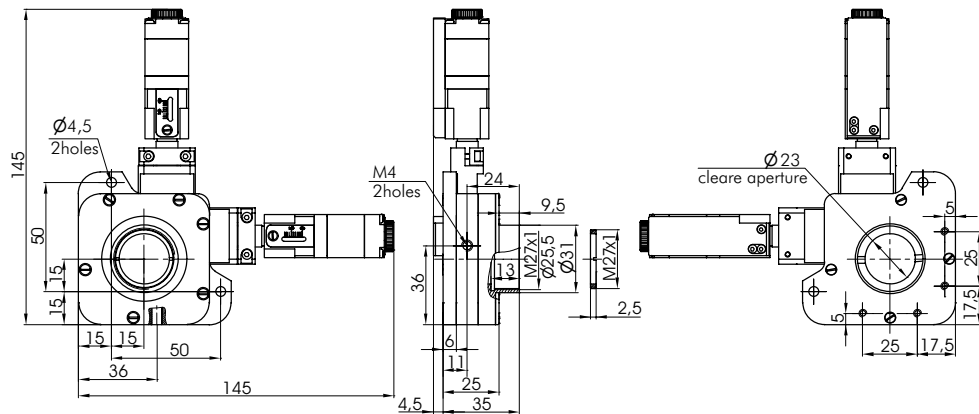

940-0200

MOTORIZED VERTICAL TRANSLATION STAGE



- **Pantograph design**
- **95 mm vertical travel range**
- **16 ball bearings**
- **Stepping motor drive**
- **Precision lead screw**

A stepper motor type – 5918, 200 steps. Customer can specify other type of motors to install.

Load capacity and speed all greatly depend on the motor. We can test and select an appropriate motor for your requirements.

The lead screw acts at a varying angle, so the resolution of the stage varies with position.

The platform has an array of M6 holes spaced by 25 mm. The base has six M6 and two Ø6.5 holes.

Material: black anodized aluminium.

Motorized Vertical Translation Stage 940-0200 boasts our unique design. Being very compact, it provides smooth and stable adjustment of height. It has a large travel range and supports large loads. While moving the platform stays parallel to the base.

Examples of use: making up for height differences during the set up; automation of technological processes, like laser welding.

Code	Price, EUR
940-0200	798