

**860-0075 VERTICAL TRANSLATION STAGE**

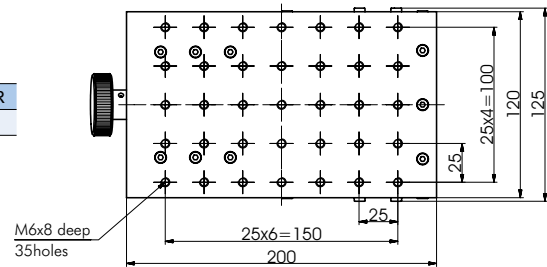
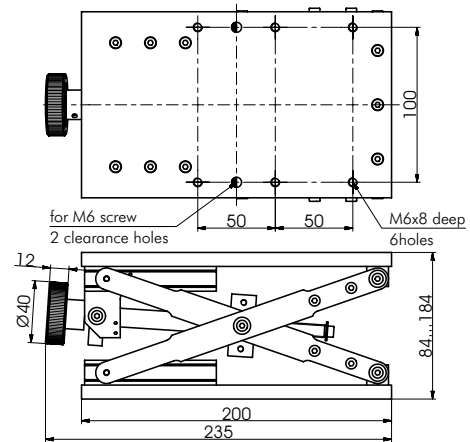

- Pantograph design
- 16 ball bearings
- Precision lead screw
- 100 mm vertical travel
- Height: min 84 mm  
max 184 mm
- Top and bottom plates parallel to 1 mm
- Load capacity 7 kg
- Weight 2.72 kg

Code	Price, EUR
860-0075	381

Vertical Translation Stage 860-0075 boasts our unique design. Being very compact, it provides smooth and stable adjustment of height. It has a large travel range, and it supports large loads. While moving the platform stays parallel to the base.

The lead screw acts at a varying angle, so the resolution of the stage varies with position.

The platform has an array of M6 holes spaced by 25 mm. The base has six M6 and two Ø6.5 holes.

Material: black anodized aluminium.