

840-0102-T SMALL OPTICAL MOUNT OF SIDE DRIVE

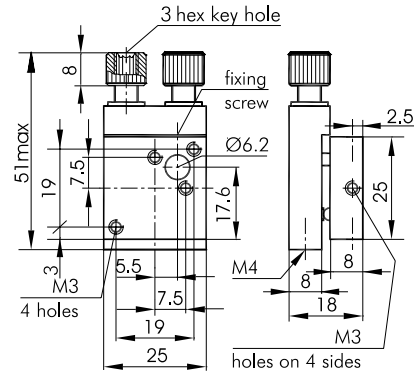

- Single side drive
- Tilt/tip $\pm 5^\circ$ about two orthogonal axes
- Fine adjustment screws with 0.25 mm pitch
- Hardened seats under adjustment screws
- Sensitivity 10 arcsec
- Large assortment of additional adapters
- Material: black anodized aluminium

840-0102T is designed to hold optics in high density schemes. Adapters are available for round and rectangular lenses, mirrors and beamsplitters or polarizing cubes (see below).
 The unit mounts on M4 hole in its base. Special Base Mounts (see below) and standard ones are available in order to mount the unit in various orientations.
 A platform has four M3 holes on its face for mounting of optics, and three M4 holes on the sides for adapters.
 Adapters with connecting cones match $\varnothing 6.2$ mm hole, where a cone is clutched by the fixing screw.
 A platform is preloaded against a base by coil springs. The mount is held together and stabilized by a flat spring.



Code	Weight, kg	Price, EUR
840-0102-T	0.05	89

Special Base Mounts 840-0100-B allow to mount 840-0102-T in different positions. 840-0102-T may be mounted as a tilt platform

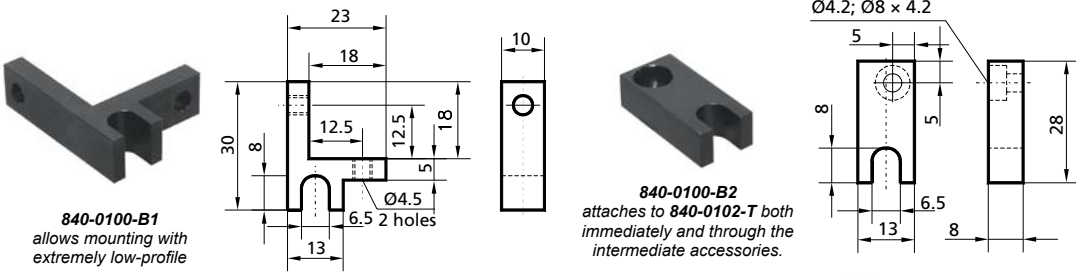

Code	Price, EUR
840-0100-B1	17
840-0100-B2	7
840-0102-T	89

