

## 810-0035

## MULTIPLE MOUNTING PLATES



Multiple Mounting Plates 810-0035 allow to assemble groups of accessories mounted in close proximity and acting as one unit (e.g. a compound lens).

For example, the slot of the plate 810-0035 allows to mount Lens Holders 830-0035 using M6 screws from beneath. Their positions can be adjusted on the plate. 810-0035 can be attached to tables, breadboards, and rods of both metric and imperial standards at the desired height and orientation. Material – black anodized aluminium.

Code	L, mm	l, mm	Weight, kg	Price, EUR
810-0035-03	300	265	0.50	27
810-0035-02	200	165	0.35	24

## Complementary Products

Code	Page
830-0035-02	8.49

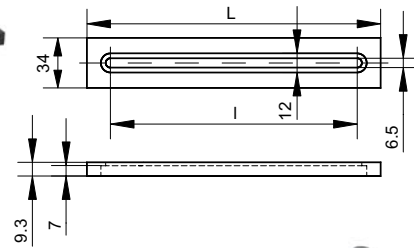

810-0035 and 830-0035

## 810-0040 • 810-0050 LARGE RODS



Large rod with rod base 810-0051



Large rod without rod base 810-0040

Code	Description	Height (H), mm	Weight, kg	Price, EUR
810-0040	Large Rod	300	1.42	31
810-0042	Large Rod	400	1.90	61
810-0050	Large Rod with black oxidized steel base	315	1.85	41
810-0051	Large Rod with stainless steel base	315	1.85	48
810-0052	Large Rod with black oxidized steel base	415	2.33	71
810-0053	Large Rod with stainless steel base	415	2.33	78

The main use of model 810-0040 precision grounded stainless steel rod is vertical positioner mounting. The 810-0050 is a large rod with rod base. These rods could be stably mounted on any surface with M6 tapped holes on 25 mm centers.

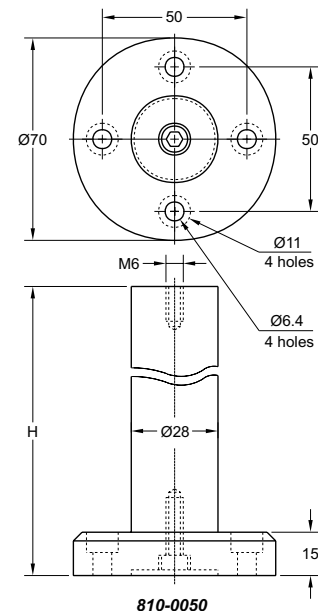

810-0050