

810-0140

ANGLE BRACKET

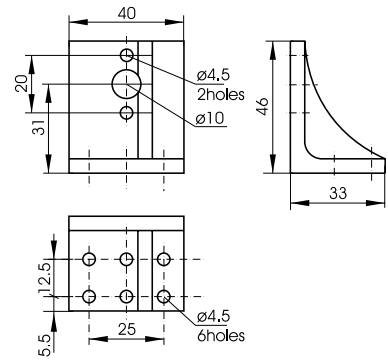

Angle Bracket 810-0140 is ideally suited for orthogonally attaching Single Axis Translation Stage 860-0092-01 to a two-Axes Translation Stage 860-0092-02 or 860-0094. 810-0140 may as well be used to attach units of other models together or to the base surfaces. 810-0140 has holes to attach translators with M4 screws. It also has a hole of Ø10mm which can serve as a clear aperture.



Code	Material	Weight, kg	Price, EUR
810-0140	Black anodized aluminium	0.06	21
810-0140SS	Stainless Steel	1.13	49

- Designed to be used with:
 - Ultra Low Profile Steel Translation Stages 860-0092
 - Low Profile Aluminium Translation Stages 860-0094

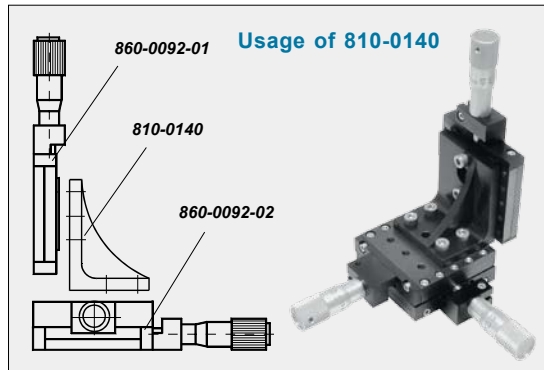

Complementary Products

Code	Page
860-0092-01	8.122
860-0092-02	8.122
860-0094	8.123

810-0145

ANGLE BRACKET

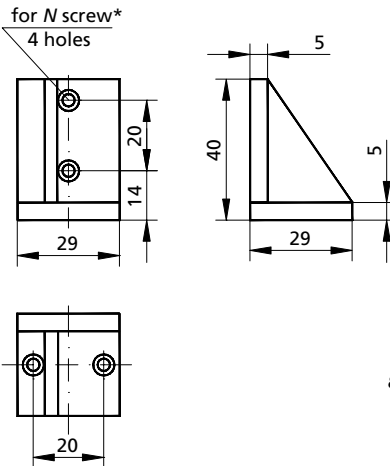

- Stainless steel
- Designed to be used with:
 - Stainless Steel Translation Stages 860-0054



Code	Weight, kg	Price, EUR
810-0145	0.13	49

* Please append letter **A** to the end of the code for 4-40 screw clearance hole or letter **B** for M3 clearance hole.

Complementary Products

Code	Page
860-0054	8.110

OPTICAL TABLES

BRACKETS & RAILS

BASE MOUNTS & ACCESSORIES

OPTICAL MOUNTS

OPTICAL POSITIONERS

BASE POSITIONERS

TRANSLATION & ROTATION STAGES

ADJUSTMENT SCREWS

MOTORIZED POSITIONERS