

**960-0130      LARGE MOTORIZED ROTATION STAGES**



- Hardened steel with aluminium body
- Large diameter ball bearings
- Worm Gear Ratio is 1:120
- Hall-effect reference limit switch
- Stepper motor or DC motor with encoder
  - Motor can be optionally equipped with reduction gear
  - 1.8 m long cable included
  - Very high load capacity
  - Vacuum version 960-0130V available on request
  - Encoders or Revolution sensors are available on request.

**SPECIFICATIONS**

Model	960-0130-01	960-0130-02	960-0130V
Rotation range	360° continuous		
Resolution in full step* in 1/8 step*	54 arcsec 6.75 arcsec		
Repeatability (bidirectional)	72 arcsec		
Backlash	40 arcsec. max.		
Maximum speed*	10 turn/min	6 turn/min	4 turn/min
Wobble	40 µRa		
Cable	1.6 m length		2 m length
Motor Connector	DB9(M)		HDB15(M)
Stepper motor	4247	5918	VSS43
Load capacity horizontal vertical	60 kg 25 kg		40 kg 20 kg
Weight	6.6 kg	5.7 kg	
Reference Hall switch	1, pushed is "closed"		

Code	Description	Weight	Price
960-0130-01	Rotation Stage with stepper motor 4247 (1.2A, 200 steps)	6.6 kg	3000 €
960-0130-02	Rotation Stage with stepper motor 5918 (2,1A, 200 steps)	5.7 kg	Request
960-0130V	Rotation Stage with stepper vacuum motor VSS43	5.7 kg	Request

### DRAWINGS OF 960-0130

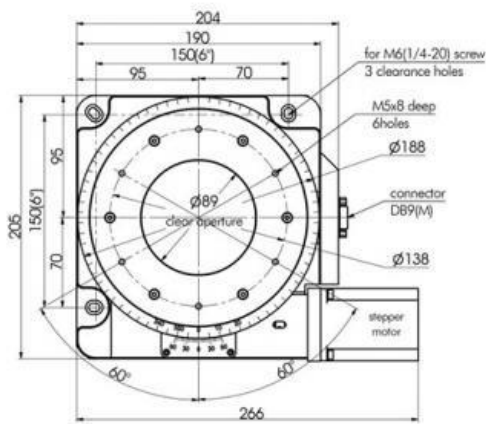
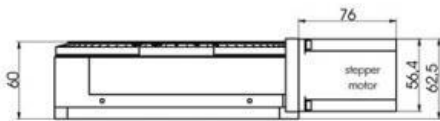

960-0130-01

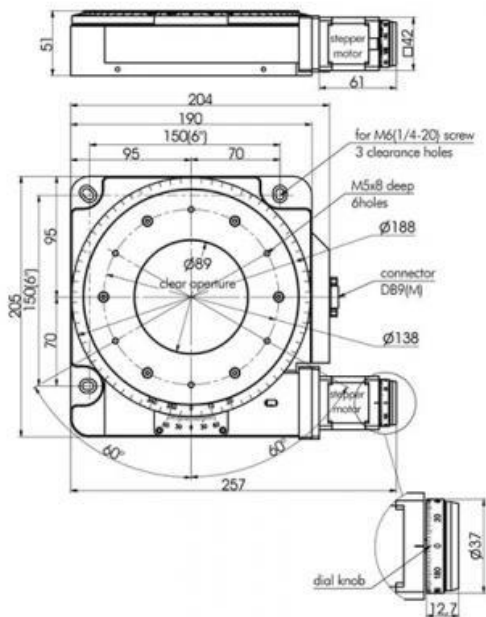

960-0130-02