

960-0095

MOTORIZED TRANSLATION STAGE



SPECIFICATIONS

Travel range	100 mm
Lead screw pitch	0.5 mm
Resolution:	
in full step*	2.5 µm
in 1/8 step*	0.31 µm
Max. speed*	10 mm/s
Load capacity:	
horizontal	40 kg
vertical	6 kg
Motor connector	DB9(M)
Stepper motor	4247
Weight	2.2 kg

***Test condition:**
• 980-0030 controllers;
• Power supply – 36 V.

Motors of other types are available.

- Huge load
- Easy use and combining
- Vacuum version available

Code	Price, EUR
960-0095	1515

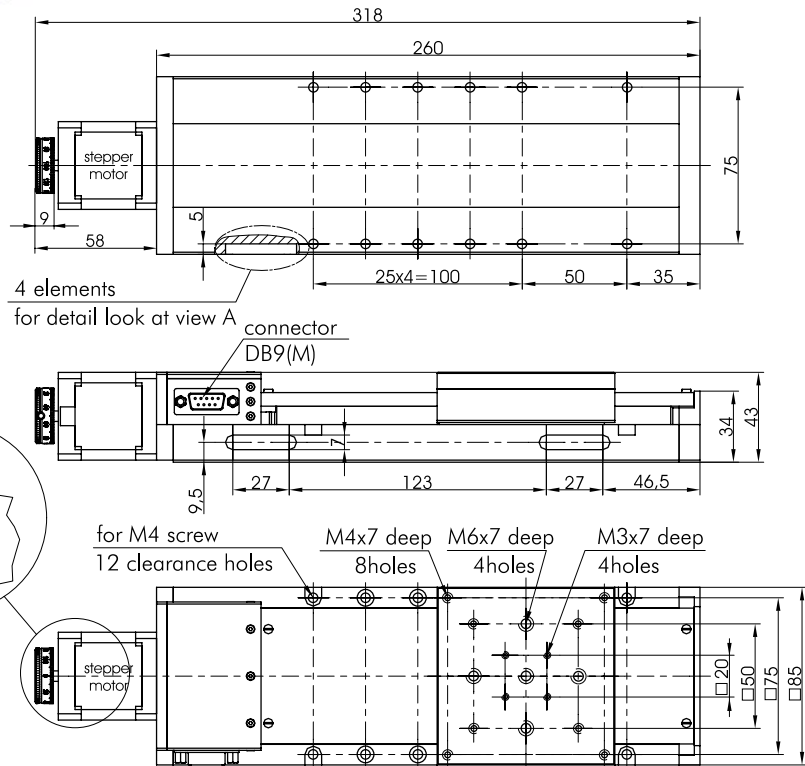

view A

960-0095

M6 screw

Optical Table

820-0125

In X-Y configuration
960-0095 stages
stack directly using
M4 screws

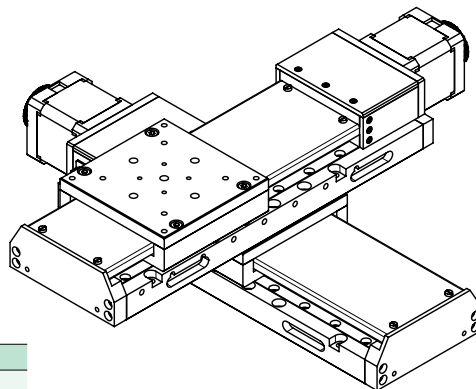

RECOMMENDED CONTROLLERS

- 980-0040-USB see page 8.189
- 980-0030-RS232 see page 8.188

Complementary Products

Code	Page
820-0125	8.37

OPTICAL
TABLES

BRACKETS &
RAILS

BASE MOUNTS &
ACCESSORIES

OPTICAL
MOUNTS

OPTICAL
POSITIONERS

BASE
POSITIONERS

TRANSLATION &
ROTATION STAGES

ADJUSTMENT
SCREWS

MOTORIZED
POSITIONERS